

**BOARD OF SUPERVISORS**  
 MARY MALLORY, CHAIRMAN – DISTRICT 5  
 BROOKS COMPTON, VICE CHAIRMAN – DISTRICT 1  
 DEE JENKINS, MEMBER – DISTRICT 2  
 NIKKI CHECK, MEMBER – DISTRICT 3  
 CHRIS KUKNYO, MEMBER – DISTRICT 4

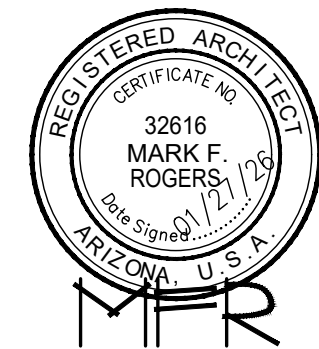

**DEVELOPMENT SERVICES**  
 JEREMY DYE, DIRECTOR  
 MARK LUSSON, ASSISTANT DIRECTOR  
 WARREN COLVIN, CHIEF BUILDING OFFICIAL

**REVIEWED FOR DESIGN  
 CRITERIA ONLY**  
 SEE ATTACHED COVER SHEET FOR ALL  
 STAMPS. IT IS THE RESPONSIBILITY OF THE  
 OWNER/APPLICANT TO REVIEW AND  
 ACKNOWLEDGE APPLICABLE STAMPS.



# HOME OF MY OWN Phase Two Single-Family Housing THREE BEDROOM / TWO BATH - LEFT PARKING

for

## YAVAPAI COUNTY, ARIZONA 1015 Fair Street Prescott, Arizona

Mark Rogers, Architect, PLLC

761 Highland Circle  
 Chino Valley, Arizona 86323  
 Phone: (928) 848-3516  
 markrogers914@gmail.com

PROPERTY OF YAVAPAI COUNTY, AZ

PROPERTY OF YAVAPAI COUNTY, AZ

INDEX TO DRAWINGS	
CS	COVER SHEET W/ PROJECT INFORMATION
A-1.0	FLOOR PLAN / OPENING SCHEDULES (Garage option)
A-1.1	FLOOR PLAN / OPENING SCHEDULES (Carport option)
A-2.0	FOUNDATION PLANS
A-3.0	ROOF FRAMING PLAN (Garage option)
A-3.1	ROOF FRAMING PLAN (Carport option)
A-4.0	BRACE WALL PLAN/CALCULATIONS (Garage option)
A-4.1	BRACE WALL PLAN/CALCULATIONS (Carport option)
A-5.0	EXTERIOR ELEVATIONS
A-6.0	BUILDING SECTIONS
A-7.0	DETAILS
M-1.0	MECHANICAL (FAU ABOVE HABITABLE AREA)
M-1.1	MECHANICAL (FAU ABOVE GARAGE/CARPORT)
E-1.0	ELECTRICAL

PROJECT INFORMATION	
ALL WORK SHALL CONFORM TO ALL YAVAPAI COUNTY ADOPTED CODES, ORDINANCES AND POLICIES, INCLUDING BUT NOT LIMITED TO THE FOLLOWING: 2024 INTERNATIONAL RESIDENTIAL CODE (IRC) 2024 INTERNATIONAL PLUMBING CODE (IPC) 2024 INTERNATIONAL MECHANICAL CODE (IMC) 2023 NATIONAL ELECTRIC CODE (NEC) 2012 INTERNATIONAL ENERGY CONSERVATION CODE (IECC)	
LIVABLE:	1,613 SQ. FT.
CARPORT/ALT. GARAGE:	483 SQ. FT.
COVERED ENTRY:	164 SQ. FT.
COVERED PATIO:	113 SQ. FT.
TOTAL UNDER ROOF:	2,373 SQ. FT.
OCCUPANCY: R-3 (Single-Family Residential) CONSTRUCTION TYPE: V-B	

THESE HOMES WERE DESIGNED FOR A MAXIMUM 40 PSF SNOW LOAD. THEY WERE NOT DESIGNED FOR A TILE ROOF.

BE ADVISED: ALTERATIONS OR MODIFICATIONS TO PLANS WILL NOT BE ACCEPTED (BEFORE OR DURING CONSTRUCTION) – NO EXCEPTIONS. IF CHANGES ARE MADE, THE ORIGINAL PERMIT WILL BE VOIDED AND A NEW CUSTOM HOME PERMIT WITH NEW PLANS ARE REQUIRED. THE NEW PERMIT WILL BE PROCESSED AS A CUSTOM HOME AND IS SUBJECT TO ALL APPLICABLE FEES AND PROCESSING TIMES (REDUCED FEES AND REVIEW TIMES WILL NO LONGER APPLY).

### GENERAL NOTES

1. DUE TO REPROGRAPHIC PROCESS, THESE PLANS MAY NOT BE ACCURATE TO SCALE. DIMENSIONS ARE NOT TO BE SCALED FROM THE WORKING DRAWINGS.
2. BEFORE ORDERING ANY MATERIALS OR STARTING ANY WORK, CONTRACTORS SHALL VERIFY ALL MEASUREMENTS AND EXISTING CONDITIONS AT THE SITE AND SHALL BE RESPONSIBLE FOR THE CORRECTNESS OF THE SAME. ANY DEVIATION AND/OR UNSAFE OR UNREGULATED CONDITIONS SHALL BE BROUGHT TO THE ATTENTION OF YAVAPAI COUNTY DEVELOPMENT SERVICES.
3. GENERAL CONTRACTOR TO VERIFY AND LOCATE ALL UTILITY STUB OUTS AND MAINS BEFORE BEGINNING CONSTRUCTION OF PROJECT.
4. GENERAL CONTRACTOR TO VERIFY THE REMOVAL AND/OR REPLANTING OF LANDSCAPE IF THE CONDITION OCCURS OVER THE PROJECT SITE.
5. DAMAGE TO SITE, UTILITIES, OR NEWLY BUILT IMPROVEMENTS, NOT DESIGNED FOR REMOVAL, SHALL BE THE RESPONSIBILITY OF THE GENERAL CONTRACTOR INVOLVED, AND SHALL BE REPAIRED OR REPLACED AT THE EXPENSE OF THE SAME.
6. VERIFY UNIFORMITY OF ALL FRAMING SO AS TO CREATE A SMOOTH, REGULAR FINISH WITH NO IRREGULARITIES.
7. IT IS THE RESPONSIBILITY OF THE GENERAL CONTRACTOR TO THOROUGHLY REVIEW THE PLANS AND TO NOTIFY YAVAPAI COUNTY DEVELOPMENT SERVICES OF ANY DISCREPANCIES. YAVAPAI COUNTY NOR THE ARCHITECT-OF-RECORD, WILL NOT BE RESPONSIBLE FOR MATERIALS IMPROPERLY ORDERED OR INSTALLED.
8. FAILURE BY THE GENERAL CONTRACTOR, OR SUB-CONTRACTORS, TO ACQUAINT THEMSELVES WITH ALL AVAILABLE INFORMATION CONCERNING THIS PROJECT SHALL NOT RELIEVE THEM OF THE RESPONSIBILITY TO PERFORM THEIR WORK PROPERLY.
9. APPROVAL OF ALL CONSTRUCTION IS SUBJECT TO FIELD VERIFICATION BY YAVAPAI COUNTY PERSONNEL.
10. EVERY SLEEPING ROOM SHALL HAVE AT LEAST ONE (1) OPERATING WINDOW OR DOOR, FOR EMERGENCY EGRESS, OPEN DIRECTLY TO A STREET, ALLEY, OR YARD.

COVER SHEET  
 PHASE TWO – 3 BDRM / 2 BATH – LEFT PARKING

YAVAPAI COUNTY, ARIZONA

1015 FAIR STREET  
 PRESCOTT, ARIZONA

SHEET NO:  
**CS**

This design is the sole property of Mark Rogers, Architect, PLLC. Use of this design has been granted to Yavapai County Government with the drawings provided. These drawings are not to be reproduced, or copied in whole or in part, for use by any entity other than Yavapai County Government. It is only to be used for the project and site specifically identified herein and is not to be used on any other project. It is to be returned upon request.

Mark Rogers, Architect, PLLC 2026©



**Mark Rogers, Architect, PLLC**

761 Highland Circle  
 ♦♦ Chino Valley, Arizona 86323  
 Phone: (928) 848-3516  
 markrogers914@gmail.com

PROPERTY OF YAVAPAI COUNTY, AZ

DOOR SCHEDULE					
DR. #	SIZE W.	H.	T.	DOOR TYPE	REMARKS
101	3'-0"	6'-8"	1-3/4"	SOLID-CORE WOOD	
102	2'-6"	6'-8"	1-3/4"	SOLID-CORE WOOD	IF USING GAS WATER HEATER, PROVIDE 12" X 12" VENTS, ONE AT THE TOP, AND BOTTOM OF DOOR
103	3'-0"	6'-8"	1-3/4"	SOLID-CORE WOOD	
104	2'-8"	6'-8"	1-3/8"	INTERIOR HOLLOW CORE	
105	2'-4"	6'-8"	1-3/8"	INTERIOR HOLLOW CORE	
106	2'-4"	6'-8"	1-3/8"	INTERIOR HOLLOW CORE	
107	2'-4"	6'-8"	1-3/8"	INTERIOR HOLLOW CORE	
108	6'-0"	6'-8"	-	SLIDING GLASS PATIO DOOR	
109	2'-6"	6'-8"	1-3/8"	INTERIOR HOLLOW CORE	
110	2'-6"	6'-8"	1-3/8"	INTERIOR HOLLOW CORE	
111	2'-4"	6'-8"	1-3/8"	INTERIOR HOLLOW CORE	
112	2'-4"	6'-8"	1-3/8"	INTERIOR HOLLOW CORE	
113	2'-6"	6'-8"	1-3/8"	INTERIOR HOLLOW CORE	
114	2'-4"	6'-8"	1-3/8"	INTERIOR HOLLOW CORE	
115	2'-4"	6'-8"	1-3/8"	INTERIOR HOLLOW CORE	
116	2'-0"	7'-0"	-	OVERHEAD GARAGE DOOR	
117	16'-0"	7'-0"	-	OVERHEAD GARAGE DOOR	
118	3'-0"	6'-8"	1-3/8"	INTERIOR HOLLOW CORE	

NOTE: WHEN USING DOOR #2 WITH THE ALTERNATE CARPORT, SELF-CLOSING & SELF-LATCHING ARE NOT REQUIRED.

**WINDOW SCHEDULE (8' plate height - 6'-8" HDR)**

WIN.	SIZE	TYPE	REMARKS
A	4040	XO	EGRESS AT BEDROOM
B	3030	XO	
C	3010	XO	
D	2030	SINGLE-HUNG	TEMPERED GLAZING
E	8040	XOX	

**WINDOW SCHEDULE (9' plate height - 8'-0" HDR)**

WIN.	SIZE	TYPE	REMARKS
A	4050	XO	EGRESS AT BEDROOM MUST HAVE MAX. 44" SILL HEIGHT ABOVE FLOOR
B	3030	XO	
C	3010	XO	
D	2030	SINGLE-HUNG	TEMPERED GLAZING
E	8050	XOX	

NOTE: FENESTRATION IN ZONE 2 (ELEVATIONS BELOW 3500 FT.) SHALL HAVE A MAXIMUM U-FACTOR OF 0.40, AND A MAXIMUM FENESTRATION SHGC FACTOR OF 0.25. FENESTRATION IN ZONE 4 (ELEVATIONS 3500 FT. AND ABOVE) SHALL HAVE A MAXIMUM U-FACTOR OF 0.35, AND A MAXIMUM FENESTRATION SHGC FACTOR OF 0.40.

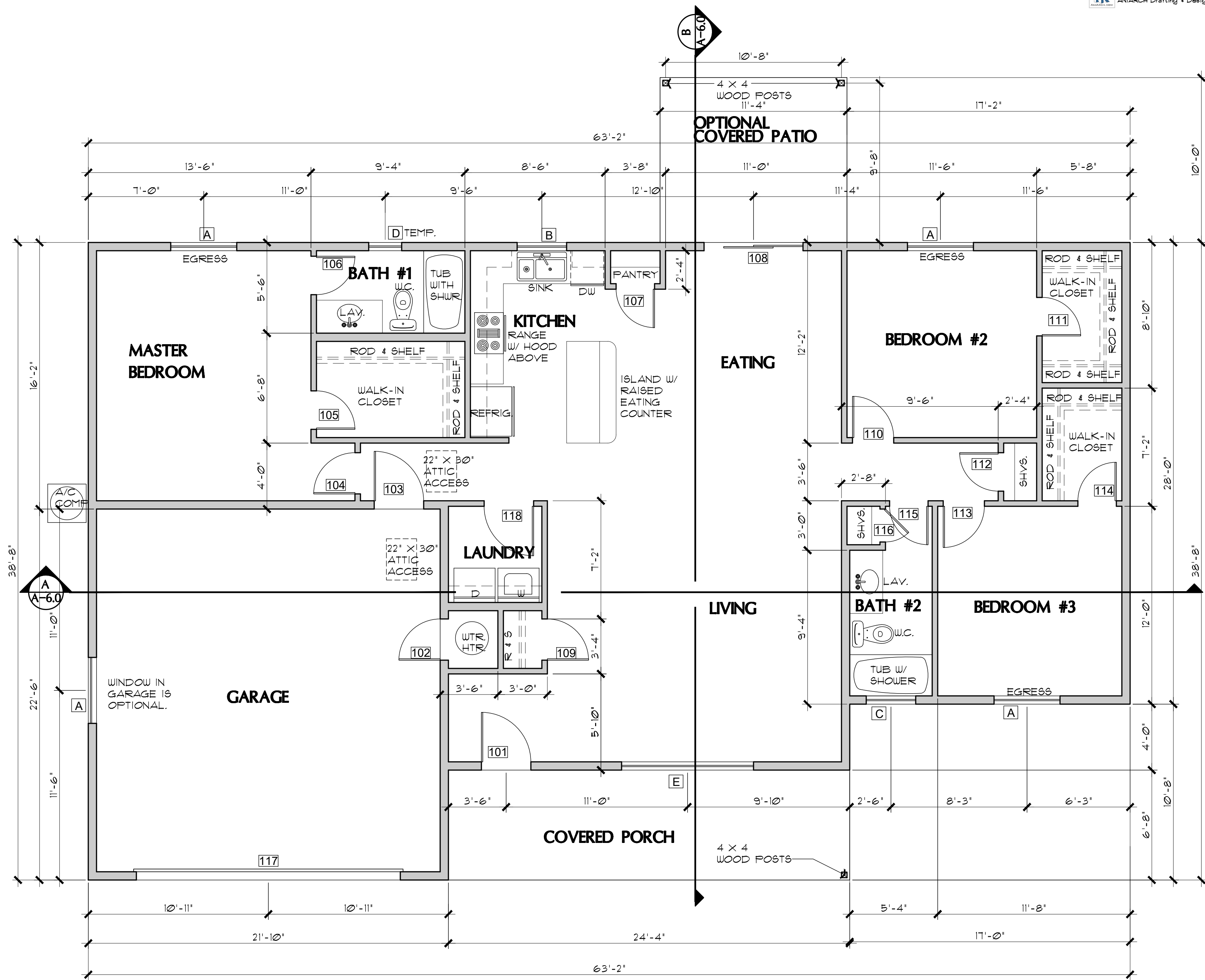

**FLOOR PLAN (with Garage option)**

SCALE: 1/4" = 1'-0"

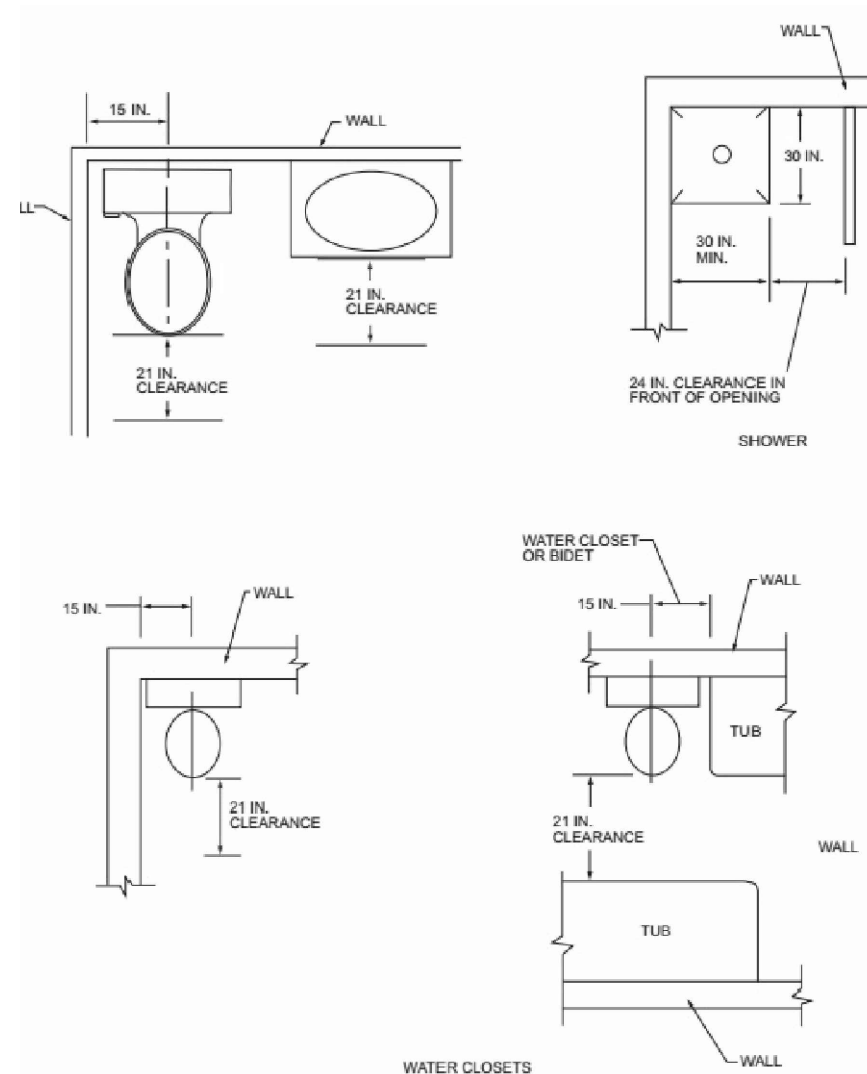

**PLUMBING FIXTURE CLEARANCES**  
 NO SCALE PER IRC FIGURE R321.1

**REVIEWED FOR DESIGN CRITERIA ONLY**  
 SEE ATTACHED COVER SHEET FOR ALL STAMPS. IT IS THE RESPONSIBILITY OF THE OWNER/APPLICANT TO REVIEW AND ACKNOWLEDGE APPLICABLE STAMPS.

**FLOOR PLAN (Garage option)  
 OPENING SCHEDULES  
 PHASE TWO - 3 BDRM / 2 BATH - LEFT PARKING**

**YAVAPAI COUNTY, ARIZONA**

1015 FAIR STREET  
 PRESCOTT, ARIZONA

SHEET NO:

**A-10**

PROPERTY OF YAVAPAI COUNTY, AZ

This design is the sole property of Mark Rogers, Architect, PLLC. Use of this design has been granted to Yavapai County Government with the drawings provided. These drawings are not to be reproduced, or copied in whole or in part, for use by any entity other than Yavapai County Government. It is only to be used for the project and site specifically identified herein and is not to be used on any other project. It is to be returned upon request.

Mark Rogers, Architect, PLLC 2026

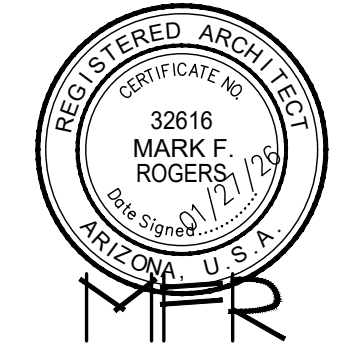

**DOOR SCHEDULE**

DR. #	SIZE			DOOR TYPE	REMARKS
	W.	H.	T.		
101	3'-0"	6'-8"	1-3/4"	SOLID-CORE WOOD	
102	2'-6"	6'-8"	1-3/4"	SOLID-CORE WOOD	IF USING GAS WATER HEATER, PROVIDE 12" X 12" VENTS, ONE AT THE TOP, AND BOTTOM OF DOOR
103	3'-0"	6'-8"	1-3/4"	SOLID-CORE WOOD	SELF-CLOSING HINGES AND SELF-LATCHING HARDWARE
104	2'-8"	6'-8"	1-3/8"	INTERIOR HOLLOW CORE	
105	2'-4"	6'-8"	1-3/8"	INTERIOR HOLLOW CORE	
106	2'-4"	6'-8"	1-3/8"	INTERIOR HOLLOW CORE	
107	2'-4"	6'-8"	1-3/8"	INTERIOR HOLLOW CORE	
108	6'-0"	6'-8"	-	SLIDING GLASS PATIO DOOR	
109	2'-6"	6'-8"	1-3/8"	INTERIOR HOLLOW CORE	
110	2'-6"	6'-8"	1-3/8"	INTERIOR HOLLOW CORE	
111	2'-4"	6'-8"	1-3/8"	INTERIOR HOLLOW CORE	
112	2'-4"	6'-8"	1-3/8"	INTERIOR HOLLOW CORE	
113	2'-6"	6'-8"	1-3/8"	INTERIOR HOLLOW CORE	
114	2'-4"	6'-8"	1-3/8"	INTERIOR HOLLOW CORE	
115	2'-4"	6'-8"	1-3/8"	INTERIOR HOLLOW CORE	
116	2'-0"	6'-8"	1-3/8"	INTERIOR HOLLOW CORE	
117	3'-0"	6'-8"	1-3/8"	INTERIOR HOLLOW CORE	

NOTE: WHEN USING DOOR #2 WITH THE ALTERNATE CARPORT, SELF-CLOSING & SELF-LATCHING ARE NOT REQUIRED.

**WINDOW SCHEDULE (8' plate height - 6'-8" HDR)**

WIN.	SIZE	TYPE	REMARKS
A	4040	XO	EGRESS AT BEDROOM
B	3030	XO	
C	3010	XO	
D	2030	SINGLE-HUNG	TEMPERED GLAZING
E	8040	XOX	

**WINDOW SCHEDULE (9' plate height - 8'-0" HDR)**

WIN.	SIZE	TYPE	REMARKS
A	4050	XO	EGRESS AT BEDROOM MUST HAVE MAX. 44" SILL HEIGHT ABOVE FLOOR
B	3030	XO	
C	3010	XO	
D	2030	SINGLE-HUNG	TEMPERED GLAZING
E	8050	XOX	

NOTE: FENESTRATION IN ZONE 2 (ELEVATIONS BELOW 3500 FT.) SHALL HAVE A MAXIMUM U-FACTOR OF 0.40, AND A MAXIMUM FENESTRATION SHGC FACTOR OF 0.25. FENESTRATION IN ZONE 4 (ELEVATIONS 3500 FT. AND ABOVE) SHALL HAVE A MAXIMUM U-FACTOR OF 0.35, AND A MAXIMUM FENESTRATION SHGC FACTOR OF 0.40.

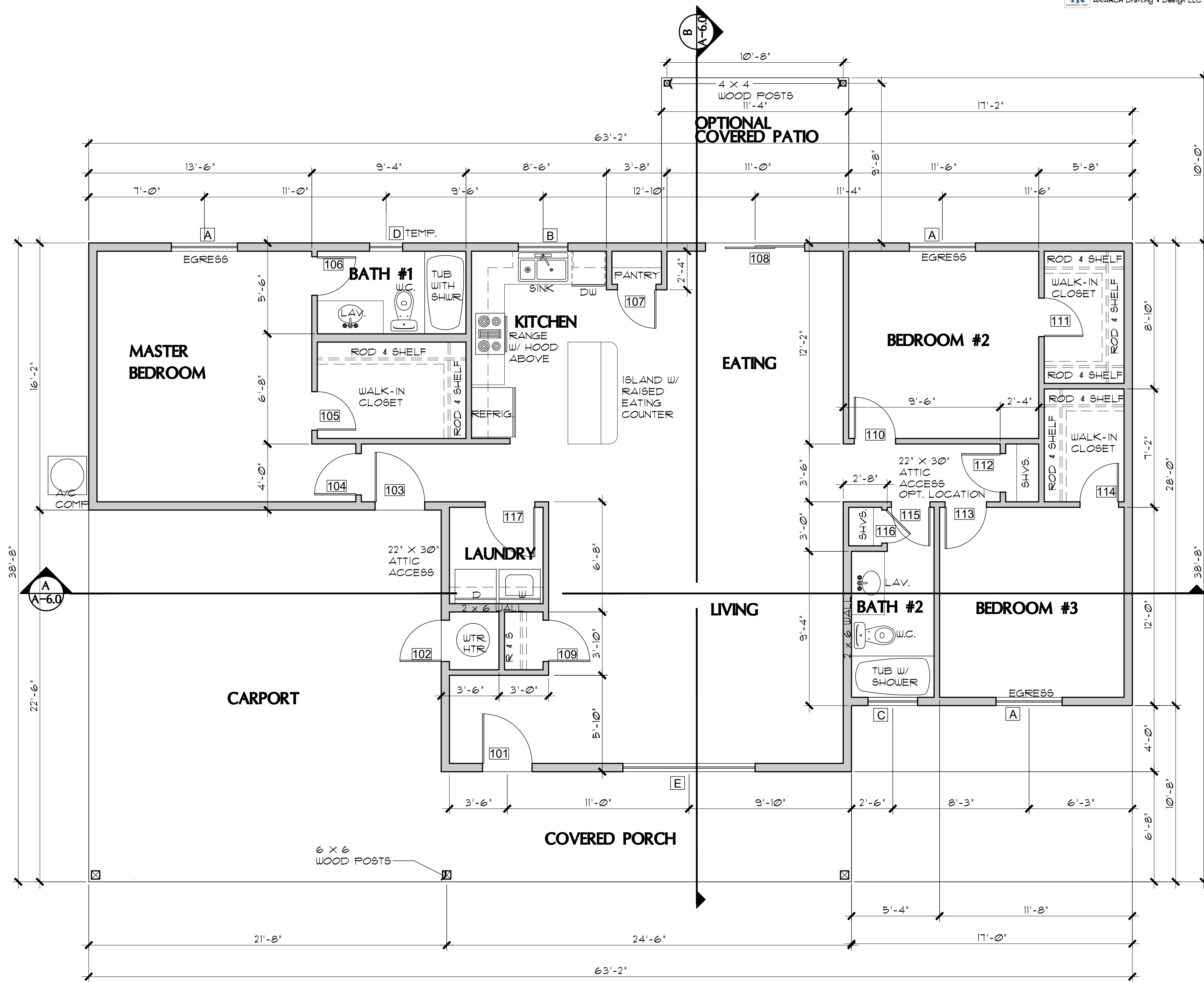

**FLOOR PLAN (with Carport option)**

SCALE: 1/4" = 1'-0"

**REVIEWED FOR DESIGN CRITERIA ONLY**  
 SEE ATTACHED COVER SHEET FOR ALL STAMPS. IT IS THE RESPONSIBILITY OF THE OWNER/APPLICANT TO REVIEW AND ACKNOWLEDGE APPLICABLE STAMPS.

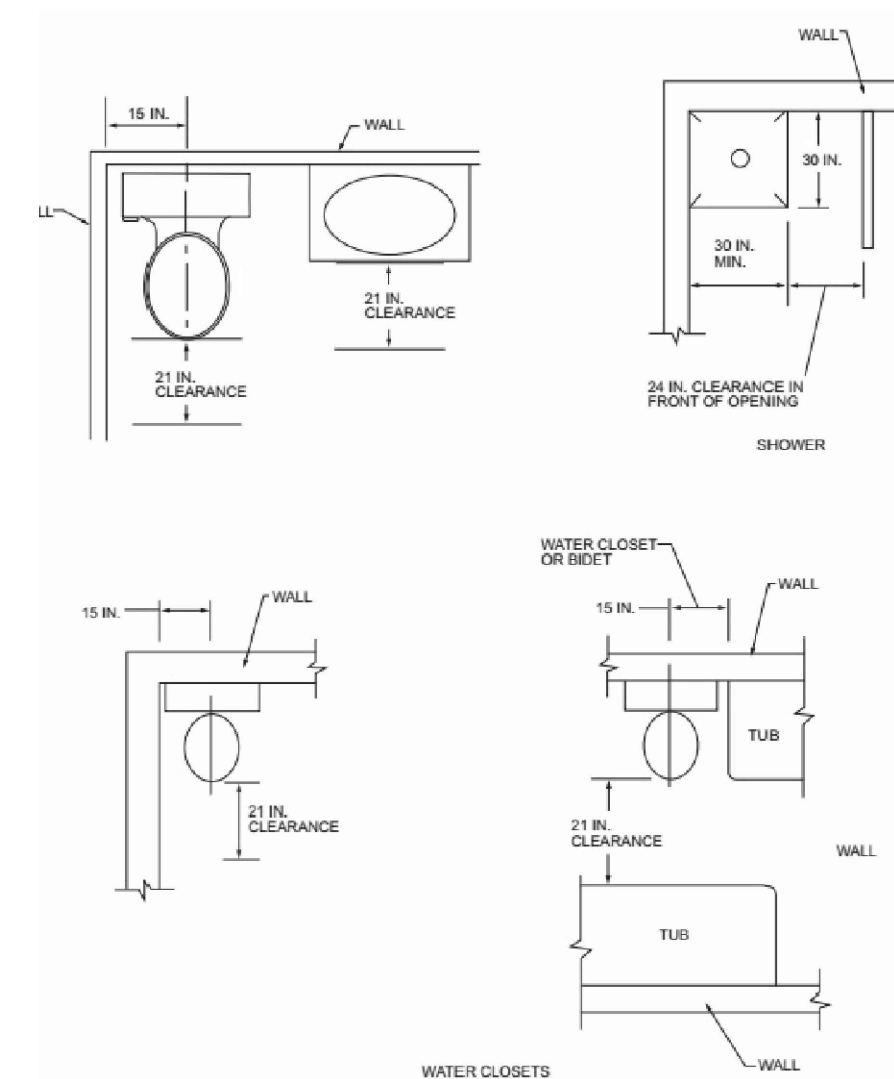

**PLUMBING FIXTURE CLEARANCES**

NO SCALE PER IRC FIGURE R32.1

**Mark Rogers, Architect, PLLC**

761 Highland Circle  
 Chino Valley, Arizona 86323  
 Phone: (928) 848-3516  
 markrogers914@gmail.com

**FLOOR PLAN (Carport option)  
 OPENING SCHEDULES  
 PHASE TWO - 3 BDRM / 2 BATH - LEFT PARKING**

**YAVAPAI COUNTY, ARIZONA**

1015 FAIR STREET  
 PRESCOTT, ARIZONA

SHEET NO:

**A-1.1**

This design is the sole property of Mark Rogers, Architect, PLLC. Use of this design has been granted to Yavapai County Government with the drawings provided. These drawings are not to be reproduced, or copied in whole or in part, for use by any entity other than Yavapai County Government. It is only to be used for the project and site specifically identified herein and is not to be used on any other project. It is to be returned upon request.

Mark Rogers, Architect, PLLC 2026©



**Mark Rogers, Architect, PLLC**

761 Highland Circle  
 ♦♦♦ Chino Valley, Arizona 86323  
 Phone: (928) 848-3516  
 markrogers914@gmail.com

**FOUNDATION PLANS**  
**PHASE TWO - 3 BDRM / 2 BATH - LEFT PARKING**

**YAVAPAI COUNTY, ARIZONA**

1015 FAIR STREET  
 PRESCOTT, ARIZONA

SHEET NO:  
**A-2.0**

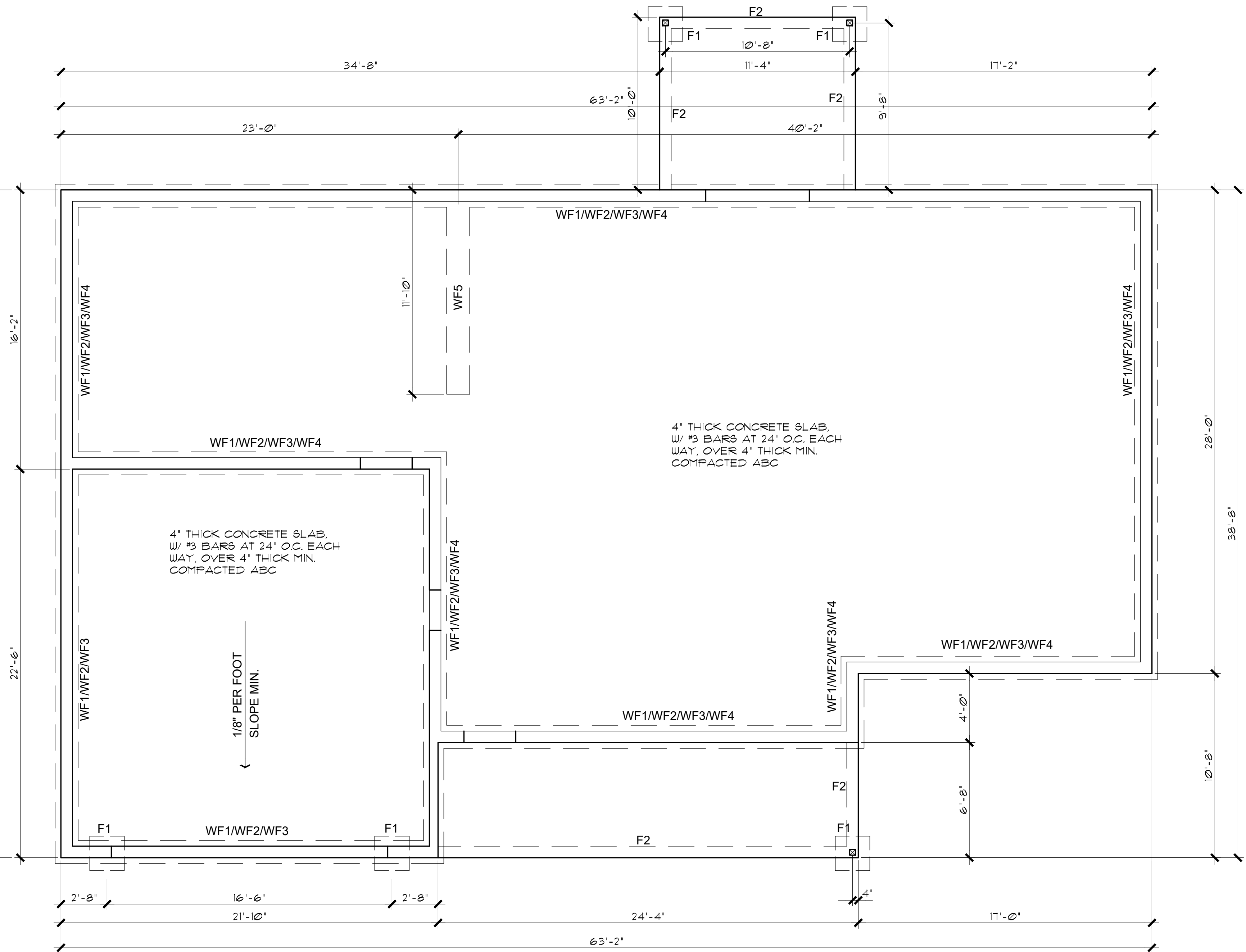

**FOUNDATION PLAN (with Garage option)**

SCALE: 1/4" = 1'-0"

SEE SHEET A-7.0 FOR FOUNDATION DETAILS

**REVIEWED FOR DESIGN CRITERIA ONLY**  
 SEE ATTACHED COVER SHEET FOR ALL STAMPS. IT IS THE RESPONSIBILITY OF THE OWNER/APPLICANT TO REVIEW AND ACKNOWLEDGE APPLICABLE STAMPS.

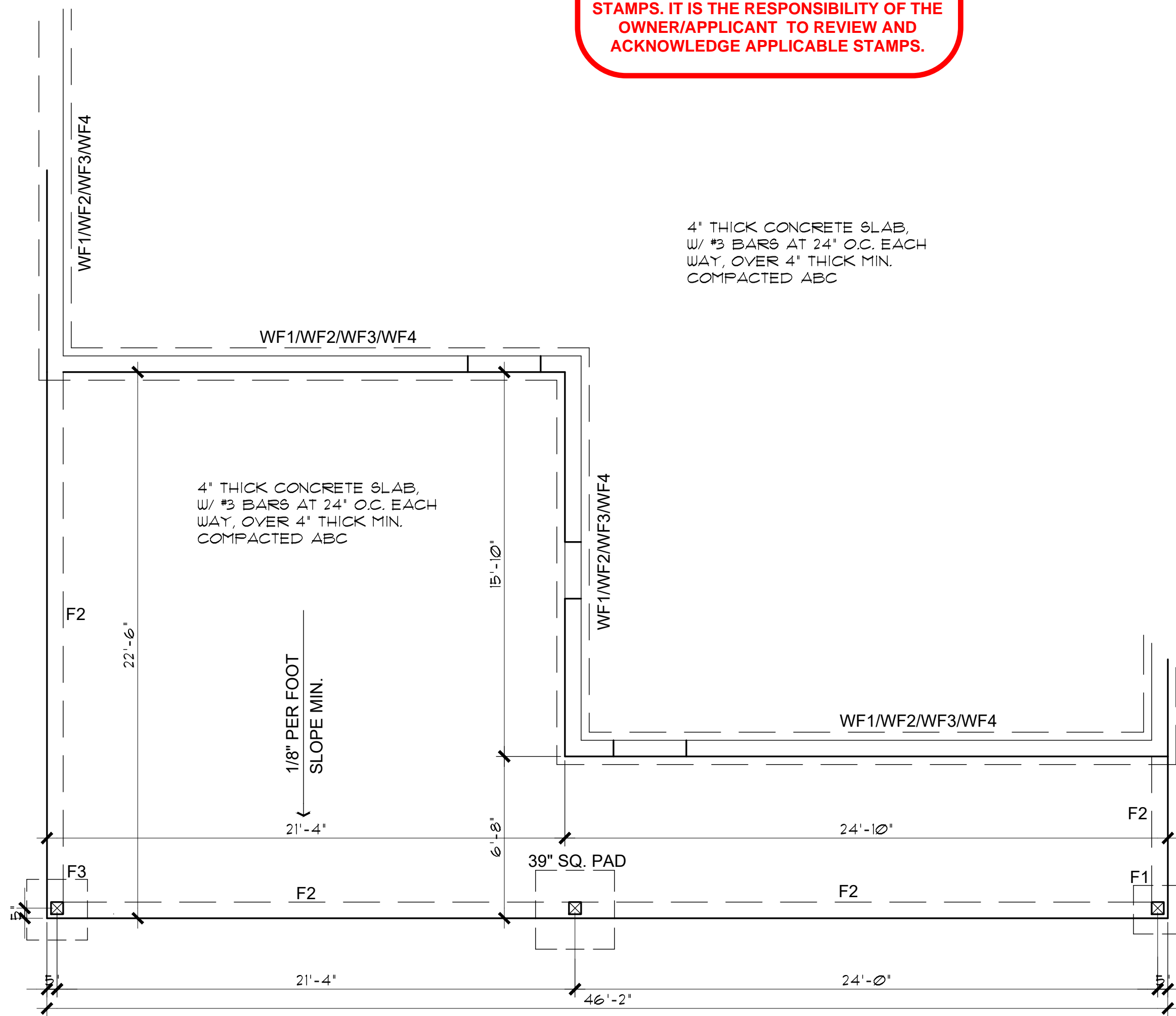

**FOUNDATION PLAN (with Carport option)**

SCALE: 1/4" = 1'-0"

**FOUNDATION NOTES**

1. FOOTINGS TO BE A MIN. OF 8" THICK IN 18" MIN. UNDISTURBED SOIL.
2. FOOTINGS AND INTERIOR FLATWORK TO BE MIN. 2500 P.S.I. MIN COMPRESSIVE STRENGTH AT 28 DAYS.
3. FOUNDATION SUPPORTED WOOD TO EXTEND MIN. 6" ABOVE FINISH GRADE
4. FOUNDATION PLATES AND SILLS SHALL BE BOLTED TO FOUNDATION WITH MIN. 1/2" BOLTS 6'-0" O.C. 12" FROM CORNERS AND EMBEDDED 1" INTO FOUNDATION WALL
5. EXTERIOR FLATWORK SLOPE TO BE 1/4" PER FOOT.
6. CONTRACTOR TO EMBED 20' OF #4 G.A. COPPER WIRE IN FOOTING FOR ELECTRICAL SERVICE GROUND.
7. THE GRADE AWAY FROM FOUNDATION WALLS SHALL FALL A MINIMUM OF 6 INCHES WITHIN THE FIRST 10 FEET.
8. ALL EXTERIOR PLATES, LOAD BEARING AND NON LOAD BEARING SHALL BE PRESSURE TREATED, LESS THAN 8" ABOVE GRADE
9. FILL BEING PLACED THAT EXCEEDS 2" WILL REQUIRE A CERTIFIED COMPACTION TEST AND REPORT.
10. VAPOR BARRIER SHALL BE INSTALLED BELOW SLAB AS PER THE GEOTECHNICAL REPORT

NOTE: THE FOOTINGS SIZE, THICKNESS, AND BOTTOM OF FOOTING DEPTH SHALL BE PER THE GEOTECHNICAL REPORT/ENGINEER'S REQUIREMENTS. THIS SHALL INCLUDE ANY OVER EXCAVATIONS, ENGINEERED PAD REQUIREMENTS, AND/OR A CHANGE IN DEPTH, AND TYPE OF BASE COURSE UNDER THE CONCRETE SLABS.

THIS PLAN IS ONLY APPLICABLE ON FLAT LOTS WITH A CROSS SLOPE NO GREATER THAN 1% ACROSS THE BUILDING PAD.

This design is the sole property of Mark Rogers, Architect, PLLC. Use of this design has been granted to Yavapai County Government with the drawings provided. These drawings are not to be reproduced, or copied in whole or in part, for use by any entity other than Yavapai County Government. It is only to be used for the project and site specifically identified herein and is not to be used on any other project. It is to be returned upon request.

Mark Rogers, Architect, PLLC 2026©



Mark Rogers, Architect, PLLC

761 Highland Circle  
 Chino Valley, Arizona 86323  
 Phone: (928) 848-3516  
 markrogers914@gmail.com

PROPERTY OF YAVAPAI COUNTY, AZ

YAVAPAI COUNTY, ARIZONA

1015 FAIR STREET  
 PRESCOTT, ARIZONA

SHEET NO:

A-3.0

- NOTES:
1. PREFAB WOOD TRUSS.
  2. WOOD STUD WALL.
  3. TRUSS EXTENSION AS OCCURS - SEE ARCHITECTURAL.
  4. PLYWOOD BLOCKING BETWEEN TRUSSES PER DETAIL 208. APPLY FULL WALL LENGTH.
  5. DOUBLE TOP PLATE.
  6. WALL SHEATHING AS OCCURS.
  7. 3-1/2" SHEAR PANEL TO TOP OF WALL.
  8. PLYWOOD SHEATHING.
  9. EDGE NAILING.
  10. SIMPSON H2.5A TYPE CONNECTOR AT EACH TRUSS.

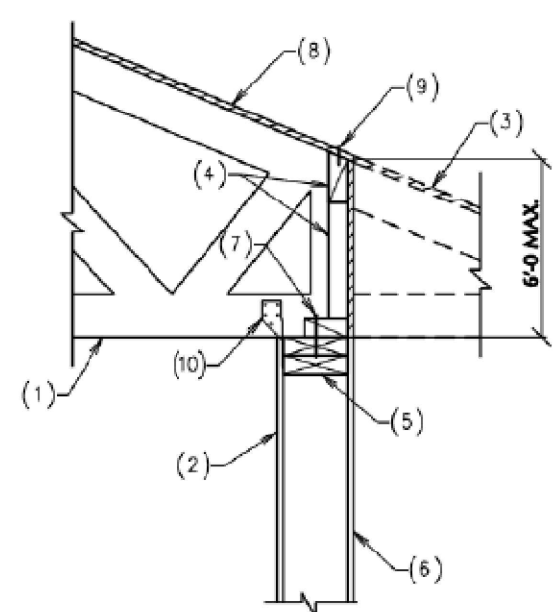

1. PREFAB WOOD TRUSS AT WOOD STUD WALL  
 NO SCALE

**REVIEWED FOR DESIGN CRITERIA ONLY**  
 SEE ATTACHED COVER SHEET FOR ALL STAMPS. IT IS THE RESPONSIBILITY OF THE OWNER/APPLICANT TO REVIEW AND ACKNOWLEDGE APPLICABLE STAMPS.

- NOTES:
1. EDGE NAILING.
  2. PREFABRICATED WOOD TRUSS. NOTE: TRUSS MANUFACTURER SHALL PROVIDE VERTICAL WEB TO MATCH LOCATION OF SHEAR PANEL.
  3. 3/8" PLYWOOD SHEAR PANEL WITH 84 AT 3" O.C. AT PANEL EDGES AND 84 AT 12" O.C. AT INTERMEDIATE SUPPORTS.
  4. 16d AT 6" O.C. TO TRUSS VERTICAL WEB.
  5. 16d TO MATCH "EDGE NAILING" SPACING.
  6. PLYWOOD SHEATHING.
  7. 2x4 AT FOUR SIDES.
  8. TOP OF WOOD PLATE OR BEAM AS OCCURS.
  9. PREFAB BLOCKING PER TRUSS MANUFACTURER, IN-PLANE SHEAR CAPACITY TO BE 200 LBS.

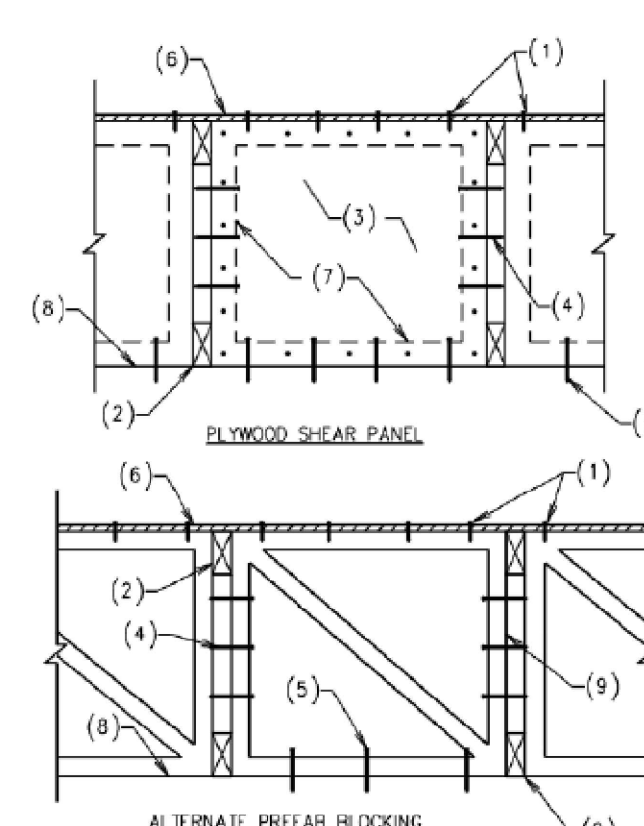

2. ELEVATION - TYPICAL PLYWOOD SHEAR PANEL BLOCKING  
 NO SCALE

**2. PANEL BLOCKING DETAIL**  
 SCALE: 1/4" = 1'-0"

1. PREFAB TRUSS PRIMARY FRAMING AT 24" O.C.
2. 2x4 VERTICAL SUPPORTS AT 4'-0" O.C. EACH WAY TO ALIGN WITH TRUSS BELOW - STAGGER SPACING AT 2'-0" O.C. AS SHOWN.
3. PLYWOOD SHEATHING.
4. EDGE NAILING.
5. (2)-16d NAILS - TYPICAL.
6. 2x8 RIDGE JOIST.
7. 2x6 JOIST AT 24" O.C.
8. CONTINUOUS 2x8 VALLEY PLATE WITH (2)-16d TO PRIMARY FRAMING.
9. 2 X SOLID BLOCKING WHERE RIDGE BOARD LANDS BETWEEN TRUSSES

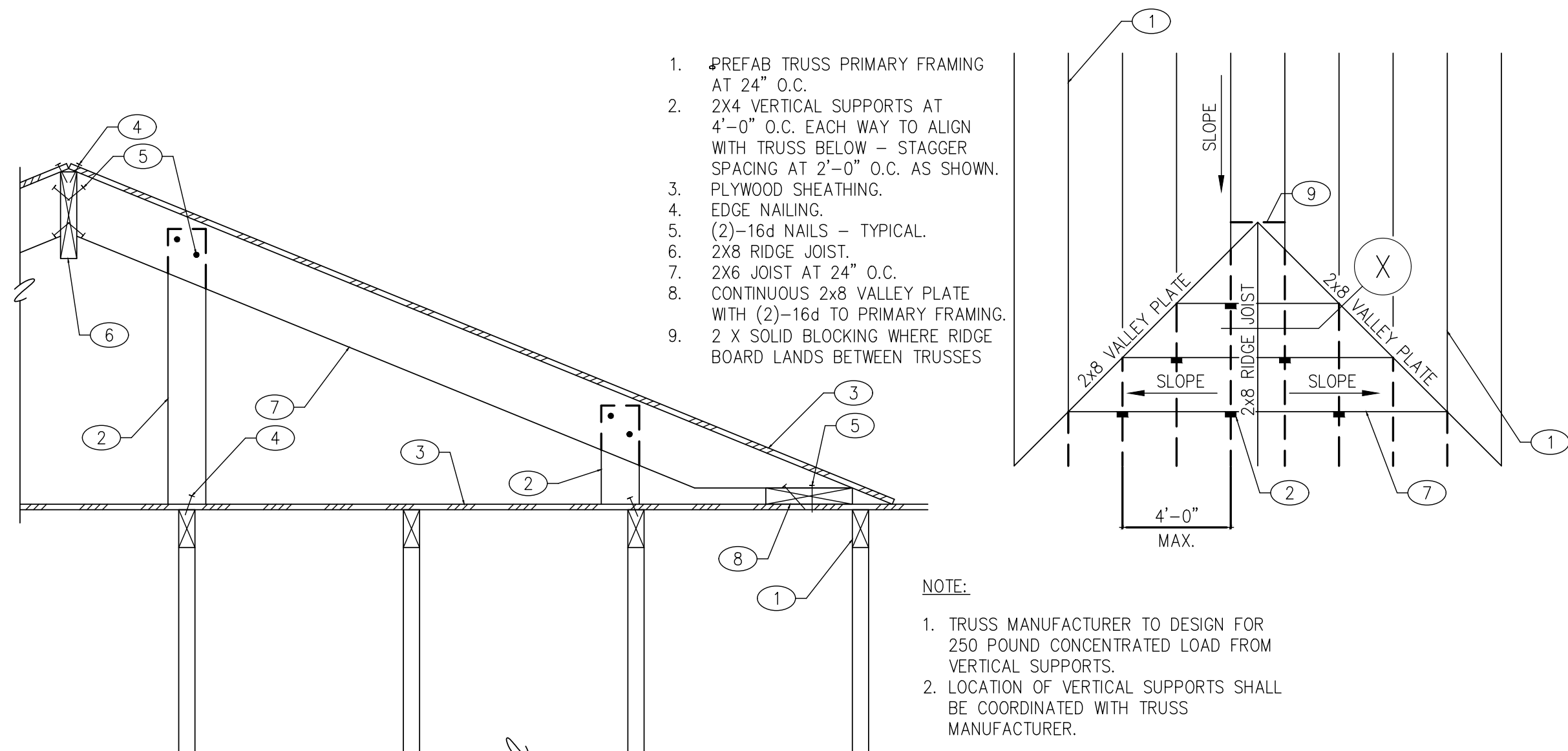

NOTE:

1. TRUSS MANUFACTURER TO DESIGN FOR 250 POUND CONCENTRATED LOAD FROM VERTICAL SUPPORTS.
2. LOCATION OF VERTICAL SUPPORTS SHALL BE COORDINATED WITH TRUSS MANUFACTURER.

NOTE: SEE SHEET A-2.0 FOR LOCATION OF VALLEY TRUSSES ON ROOF FRAMING PLAN.

**3. TYPICAL VALLEY TRUSS OVERFRAME DETAIL**  
 SCALE: 1/4" = 1'-0"

**ROOF FRAMING PLAN (with optional Garage)**  
 SCALE: 1/4" = 1'-0"

SCALE: 1/4" = 1'-0"



**ROOF NOTES**

1. REFER TO TRUSS CALCULATIONS FOR FINAL ROOF FRAMING DESIGN.
2. SIMPSON H2.5A HANGERS TO BE APPLIED @ ALL TRUSS ENDS.
3. SUPPORTED MEMBERS OF G.L.B., 4 GIRDERS, OR OTHER CONCENTRATED LOADS SUPPORTED BY WALL OR PIER SHALL HAVE BEARING AT LEAST AS WIDE AS THE ROOF MEMBER.
4. ROOF SHEATHING TO BE 1/2" CDX PLYWOOD OR OSB.
5. ROOF PITCH 4:12 (TYP.).
6. OVERHANGS TO BE 24".
7. FURNACE IN ATTIC: PROVIDE A 24" SOLID PASSAGEWAY TO CONTROL SIDE OF APPLIANCE AND A 30" SERVICE SPACE ON THE CONTROL SIDE OF THE APPLIANCE (REQUIRED FOR ATTIC MOUNT FURNACES).
8. ALL RAFTERS SHALL BE DOUGLAS FIR #2 (SIZE PER PLAN). ALL STUDS SHALL BE PLYM FIR #2 (SIZE PER PLAN).
9. DOWNSPOUT/ROOF DRAIN DISCHARGE SHALL TERMINATE AS RECOMMENDED BY THE GEOTECHNICAL REPORT.

SEE ROOF FRAMING DETAILS SHEET A7.0

NOTE: PROVIDE PANEL EDGE SUPPORT FOR NARROW-WIDTH ROOF SHEATHING PER APA TECHNICAL REPORT #R275A.

**BRACED WALL PANEL CONNECTION OPTION AT PERPENDICULAR ROOF TRUSSES**  
 SCALE: 1 1/2" = 1'-0"

SCALE: 1 1/2" = 1'-0"

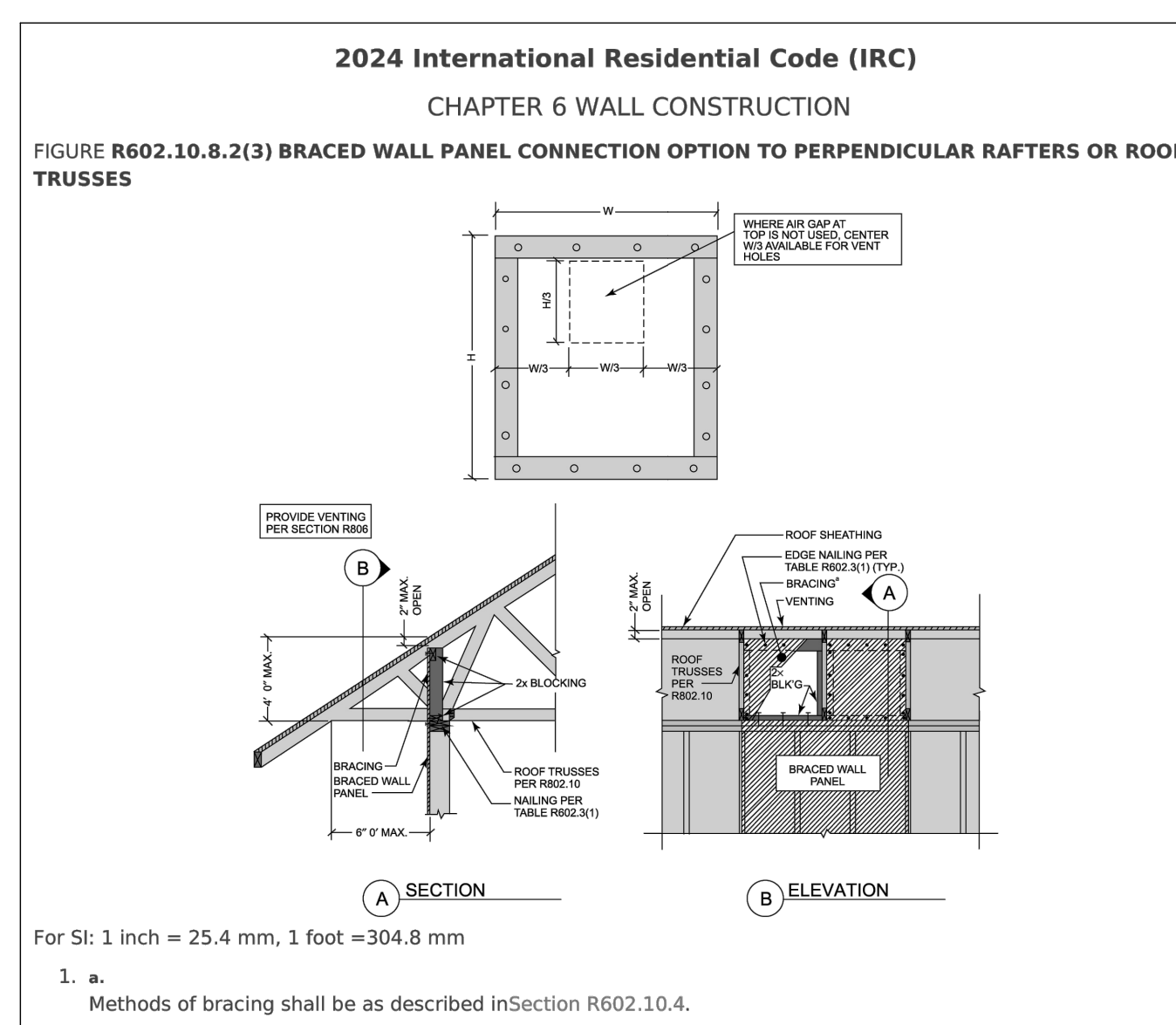

**1. BRACED WALL PANEL CONNECTION OPTION AT PERPENDICULAR ROOF TRUSSES**  
 SCALE: 1 1/2" = 1'-0"

2024 IRC FIGURE R602.10.8.2(3)

This design is the sole property of Mark Rogers, Architect, PLLC. Use of this design has been granted to Yavapai County Government with the drawings provided. These drawings are not to be reproduced, or copied in whole or in part, for use by any entity other than Yavapai County Government. It is only to be used for the project and site specifically identified herein and is not to be used on any other project. It is to be returned upon request.

Mark Rogers, Architect, PLLC 2026©



**REVIEWED FOR DESIGN CRITERIA ONLY**  
 SEE ATTACHED COVER SHEET FOR ALL STAMPS. IT IS THE RESPONSIBILITY OF THE OWNER/APPLICANT TO REVIEW AND ACKNOWLEDGE APPLICABLE STAMPS.

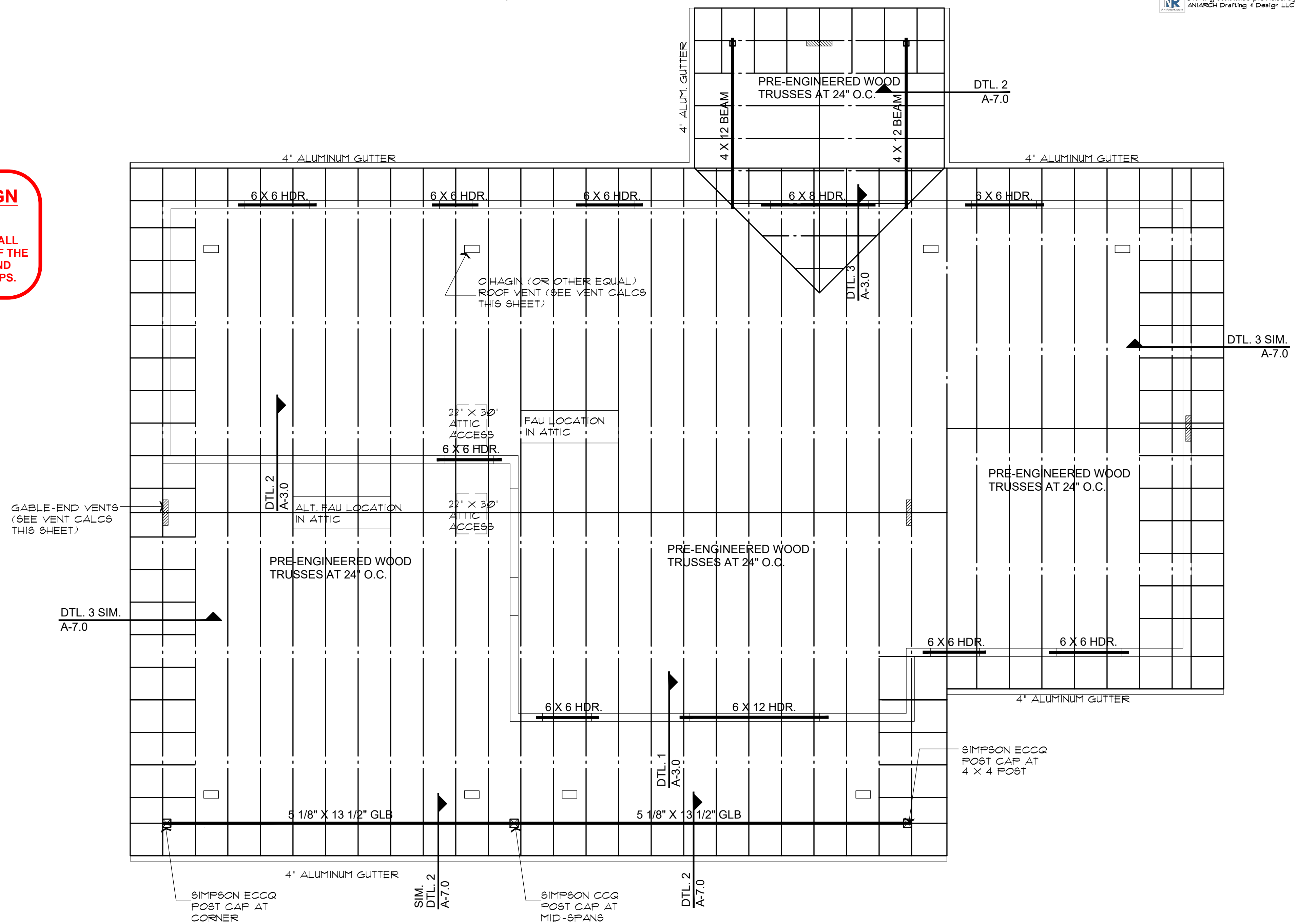

**ROOF FRAMING PLAN (with optional Carport)**

SCALE: 1/4" = 1'-0"

NOTE: PROVIDE PANEL EDGE SUPPORT FOR NARROW-WIDTH ROOF SHEATHING PER APA TECHNICAL REPORT #R275A.

ROOF VENTILATION REQUIRED 2373 SQ. FT. / 300 = 8 SQ. FT. (1152 SQ. IN.)  
 USE 4 GABLE-END VENTS AT 144 SQ. IN. MINIMUM EACH VENT 576 SQ. IN. AT GABLE ENDS  
 8 O'HAGIN OR OTHER EQUAL LOW VENTS AT 72 SQ. IN. EACH 576 SQ. IN. LOW VENTS  
 BIRDBLOCKS TO HAVE 3 HOLES, 2" DIA. EACH BOARD

**ROOF NOTES**

- REFER TO TRUSS CALCULATIONS FOR FINAL FRAMING DESIGN.
- SIMPSON H2.5A HANGERS TO BE APPLIED @ ALL TRUSS ENDS
- ROOF SHEATHING TO BE 1/2" CDX PLYWOOD OR OSB.
- SUPPORTED MEMBERS OF G.L.B., 4 GIRDERS OR OTHER CONCENTRATED LOADS SUPPORTED BY WALL OR PIER SHALL HAVE BEARING AT LEAST AS WIDE AS THE ROOF MEMBER.
- ROOF PITCH 4:12 (TYP.).
- OVERHANGS TO BE 24".
- FURNACE IN ATTIC: PROVIDE A 24" SOLID PASSAGEWAY TO CONTROL SIDE OF APPLIANCE AND A 30" SERVICE SPACE ON THE CONTROL SIDE OF THE APPLIANCE (REQUIRED FOR ATTIC MOUNT FURNACES)
- ALL RAFTERS SHALL BE DOUGLAS FIR #2 (SIZE PER PLAN) ALL STUDS SHALL BE HEM FIR #2 (SIZE PER PLAN)
- DOWNSPOUT/ROOF DRAIN DISCHARGE SHALL TERMINATE AS RECOMMENDED BY THE GEOTECHNICAL REPORT

SEE ROOF FRAMING DETAILS SHEET A7.0

Mark Rogers, Architect, PLLC

761 Highland Circle  
 Chino Valley, Arizona 86323  
 Phone: (928) 848-3516  
 markrogers914@gmail.com

ROOF FRAMING PLAN (Carport option)  
 PHASE TWO - 3 BDRM / 2 BATH - LEFT PARKING

YAVAPAI COUNTY, ARIZONA

1015 FAIR STREET  
 PRESCOTT, ARIZONA

SHEET NO:

**A-3.1**



This design is the sole property of Mark Rogers, Architect, PLLC. Use of this design has been granted to Yavapai County Government with the drawings provided. These drawings are not to be reproduced, or copied in whole or in part, for use by any entity other than Yavapai County Government. It is only to be used for the project and site specifically identified herein and is not to be used on any other project. It is to be returned upon request.

Mark Rogers, Architect, PLLC 2026

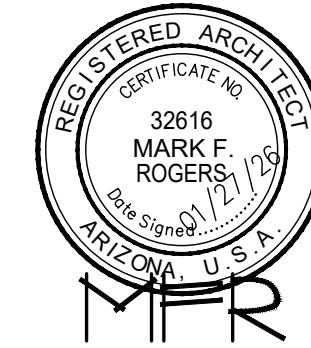

**Mark Rogers, Architect, PLLC**

761 Highland Circle  
 Chino Valley, Arizona 86323  
 Phone: (928) 848-3516  
 markrogers914@gmail.com

**BRACE WALL PLAN - CARPORT OPTION  
 CALCULATIONS  
 PHASE TWO - 3 BDRM / 2 BATH - LEFT PARKING**

**YAVAPAI COUNTY, ARIZONA**

1015 FAIR STREET  
 PRESCOTT, ARIZONA

WIND SPEED (MPH)		110		110		110		110		110		
BRACED WALL LINE		A		B		C						
STORY												
BRACED WALL PANEL METHOD		WSP SFB PCF HPS CS-SFB		GB		CS-WSP CS-PF CS-G						
AVG BWL SPACING (ft)		21.5		41.66		41.66						
TABULAR REQUIRED (ft)		3.72		11.91		5.75						
ADJUSTMENT	EXPOSURE	C	1.20	C	1.20	C	1.20	C		C		
	EAVE-RIDGE HT (ft)	7.00	0.82	7.00	0.82	7.00	0.82					
	STORY HEIGHT (ft)	9.00	0.95	9.00	0.95	9.00	0.95					
	# BWLs	3.00	1.30	3.00	1.30	3.00	1.30					
	ADD PAIR 800# HOLD DOWNS	NO	1.00	NO	1.00	NO	1.00					
	OMIT INTERIOR GB	NO	1.00	NO	1.00	NO	1.00					
	METHOD GB FASTEN @ 4" o.c.	NO	1.00	NO	1.00	NO	1.00					
HORIZONTAL BLOCKING OMITTED	NO	1.00	NO	1.00	NO	1.00						
REQUIRED BWP LENGTH (ft)		4.53		14.48		6.99						
ACTUAL BWP	CONTRIBUTING LENGTH	BWP	METHOD	LENGTH (ft)	METHOD	LENGTH (ft)	METHOD	LENGTH (ft)	METHOD	LENGTH (ft)	METHOD	LENGTH (ft)
		1	CS-WSP	4.00	DS-GB	5.83	CS-WSP	4.00				
		2	CS-WSP	4.00	CS-WSP	6.00	CS-WSP	4.00				
		3				CS-WSP	6.00					
		4										
		5										
		6										
ACTUAL BWP LENGTH (ft)		8.00		17.83		8.00						
ACTUAL ≥ REQUIRED		YES		YES		YES						
SPACE	BWPs ≤ 20' APART	YES		YES		YES						
# of BWPs	Length of BWL (ft)	16.16		32		28						
	BWP 1 ≤ 16', 2 > 16'	YES		YES		YES						
ENDS	BWP WITHIN 10' OF END	YES	YES	YES	YES	YES	YES	YES	YES			
	CONTINUOUS END CONDITION	3	3	3	3	4	3					
BWL COMPLIANCE PASS-FAIL		PASS		PASS		PASS						

WIND SPEED (MPH)		110		110		110		110		110		
BRACED WALL LINE		1		2		3						
STORY												
BRACED WALL PANEL METHOD		CS-WSP CS-PF CS-G		WSP SFB PCF HPS CS-SFB		CS-WSP CS-PF CS-G						
AVG BWL SPACING (ft)		28		16.16		15.83						
TABULAR REQUIRED (ft)		4.20		2.92		2.37						
ADJUSTMENT	EXPOSURE	C	1.20	C	1.20	C	1.20	C		C		
	EAVE-RIDGE HT (ft)	7.00	0.82	7.00	0.82	7.00	0.82					
	STORY HEIGHT (ft)	9.00	0.95	9.00	0.95	9.00	0.95					
	# BWLs	3.00	1.30	3.00	1.30	3.00	1.30					
	ADD PAIR 800# HOLD DOWNS	NO	1.00	NO	1.00	NO	1.00					
	OMIT INTERIOR GB	NO	1.00	NO	1.00	NO	1.00					
	METHOD GB FASTEN @ 4" o.c.	NO	1.00	NO	1.00	NO	1.00					
HORIZONTAL BLOCKING OMITTED	NO	1.00	NO	1.00	NO	1.00						
REQUIRED BWP LENGTH (ft)		5.10		3.55		2.89						
ACTUAL BWP	CONTRIBUTING LENGTH	BWP	METHOD	LENGTH (ft)	METHOD	LENGTH (ft)	METHOD	LENGTH (ft)	METHOD	LENGTH (ft)	METHOD	LENGTH (ft)
		1	CS-WSP	4.00	CS-WSP	4.00	CS-WSP	4.00				
		2	CS-WSP	4.00	CS-WSP	4.00	CS-WSP	4.00				
		3	CS-WSP	4.00			CS-WSP	4.00				
		4	CS-WSP	4.00								
		5										
		6										
ACTUAL BWP LENGTH (ft)		16.00		8.00		12.00						
ACTUAL ≥ REQUIRED		YES		YES		YES						
SPACE	BWPs ≤ 20' APART	YES		YES		YES						
# of BWPs	Length of BWL (ft)	63.16		21.5		41.66						
	BWP 1 ≤ 16', 2 > 16'	YES		YES		YES						
ENDS	BWP WITHIN 10' OF END	YES	YES	YES	YES	YES	YES	YES	YES			
	CONTINUOUS END CONDITION	3	3	3	1	4	3					
BWL COMPLIANCE PASS-FAIL		PASS		PASS		PASS						

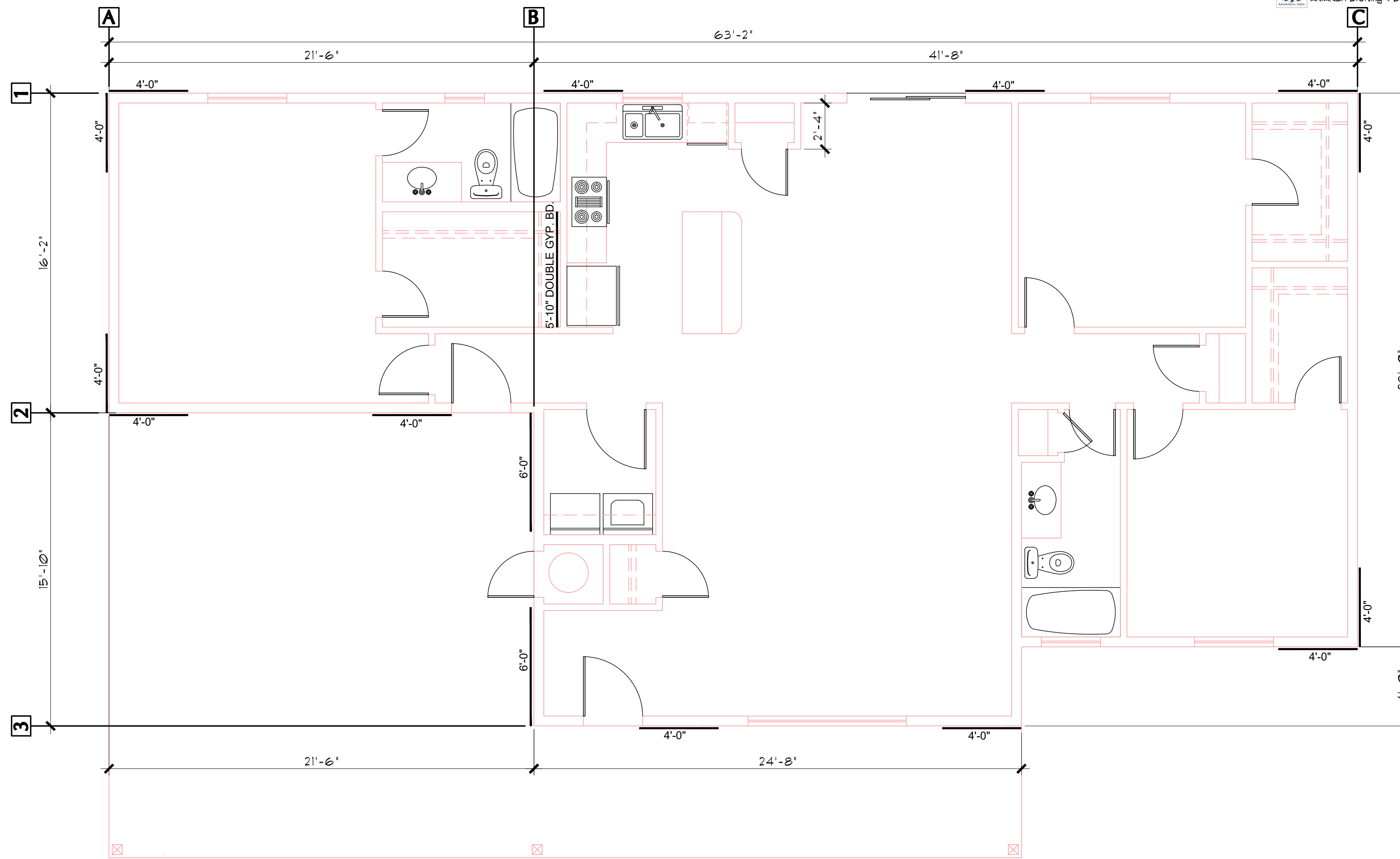

**BRACE WALL PLAN (with Carport option)**

SCALE: 1/4" = 1'-0"

OPTIONS FOR EXTERIOR SIDING-  
 OPTION #1:  
 5/8" THICK T1-11, SIDING, 12" MINIMUM GROOVE SPACING. THE T1-11 MAY SERVE AS THE BRACE WALL PANELS, PROVIDED THE CODE REQUIRED NAILING PATTERN IS APPLIED. SEE DETAIL #1, A-6.0

OPTION #2:  
 MINIMUM 3/8" THICK "LP SMART SIDING". (SEE DTL. #1, A-6.0)

OPTION #3:  
 STUCCO OVER WEATHER BARRIER, OVER 1/2" PLYWOOD SEE DETAIL #2, A-6.0)

OPTION #4:  
 HORIZ. SIDING OVER WEATHER BARRIER, OVER 1/2" PLYWOOD SEE DETAIL #3, A-6.0)

**REVIEWED FOR DESIGN  
 CRITERIA ONLY**

SEE ATTACHED COVER SHEET FOR ALL STAMPS. IT IS THE RESPONSIBILITY OF THE OWNER/APPLICANT TO REVIEW AND ACKNOWLEDGE APPLICABLE STAMPS.

**REVIEWED FOR DESIGN  
CRITERIA ONLY**

SEE ATTACHED COVER SHEET FOR ALL STAMPS. IT IS THE RESPONSIBILITY OF THE OWNER/APPLICANT TO REVIEW AND ACKNOWLEDGE APPLICABLE STAMPS.

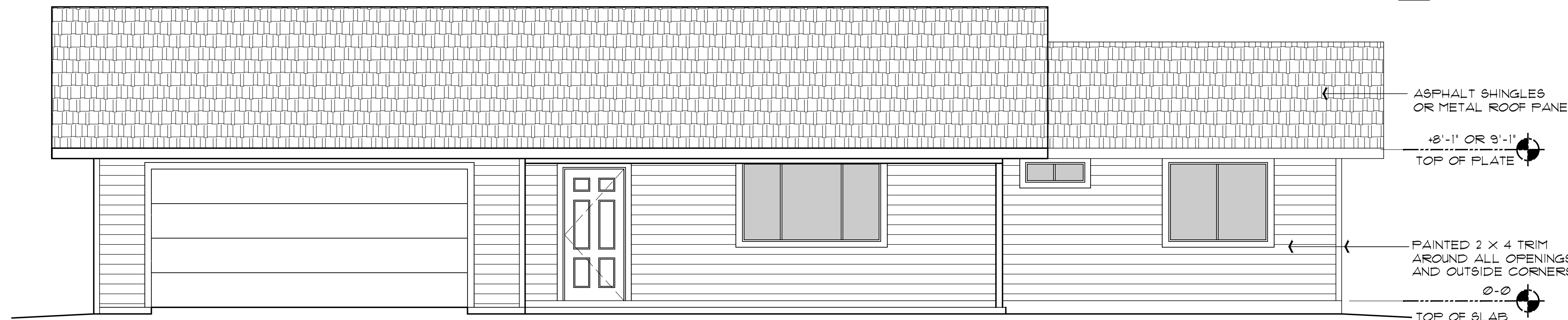

**FRONT ELEVATION (with optional Garage)**

SCALE: 1/4" = 1'-0"



**PARTIAL FRONT ELEVATION (with optional Carport)**

SCALE: 1/4" = 1'-0"

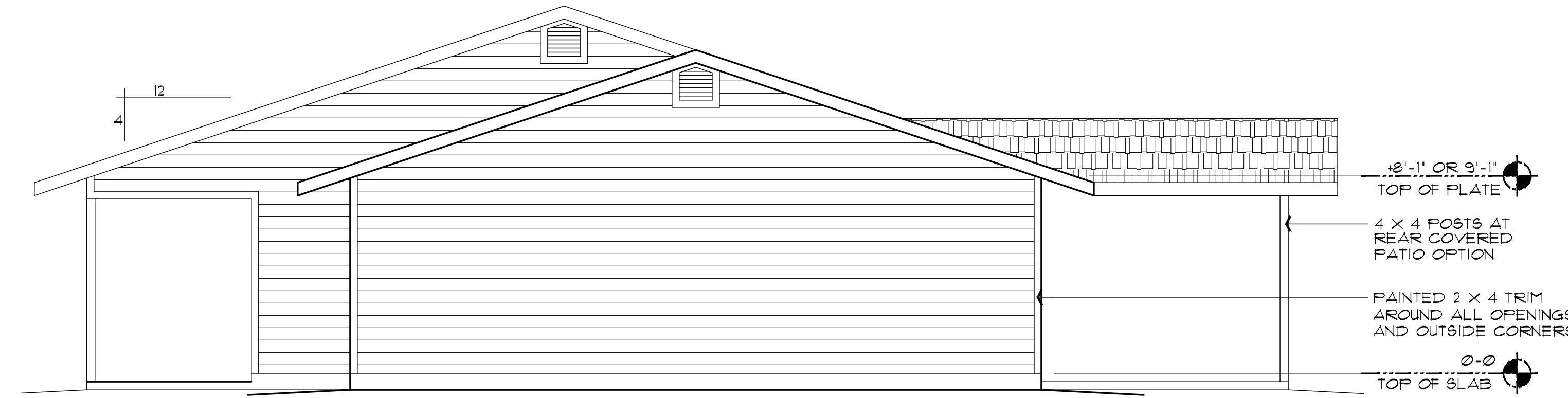

**RIGHT SIDE ELEVATION (same with both options)**

SCALE: 1/4" = 1'-0"

SEE SHEET A-6.0 FOR SIDING OPTIONS

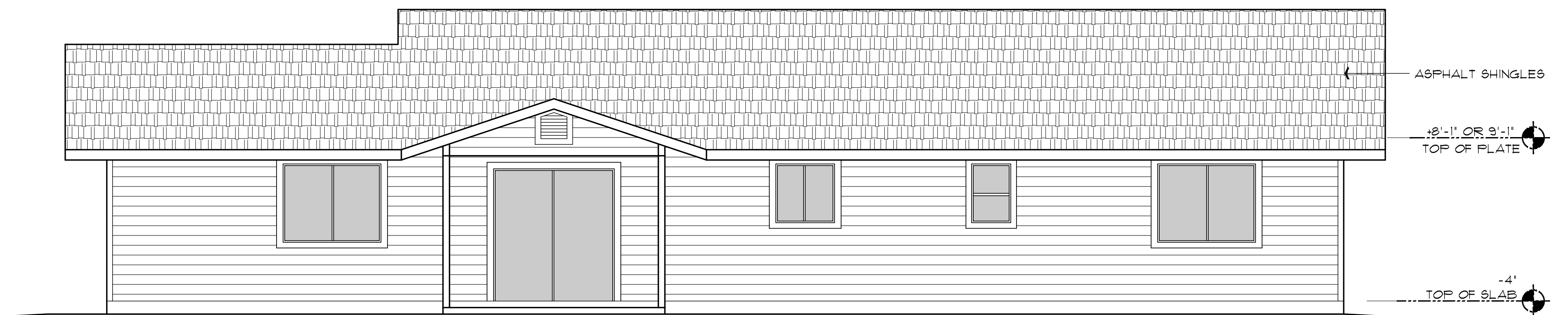

**REAR ELEVATION (with optional Garage)**

SCALE: 1/4" = 1'-0"

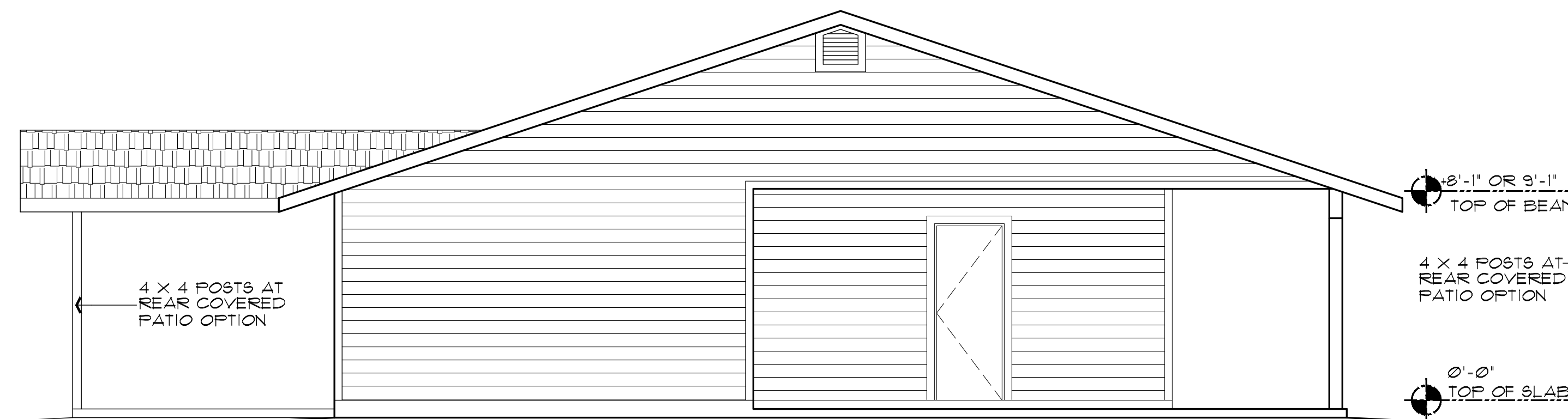

**LEFT SIDE ELEVATION (with optional Carport)**

SCALE: 1/4" = 1'-0"

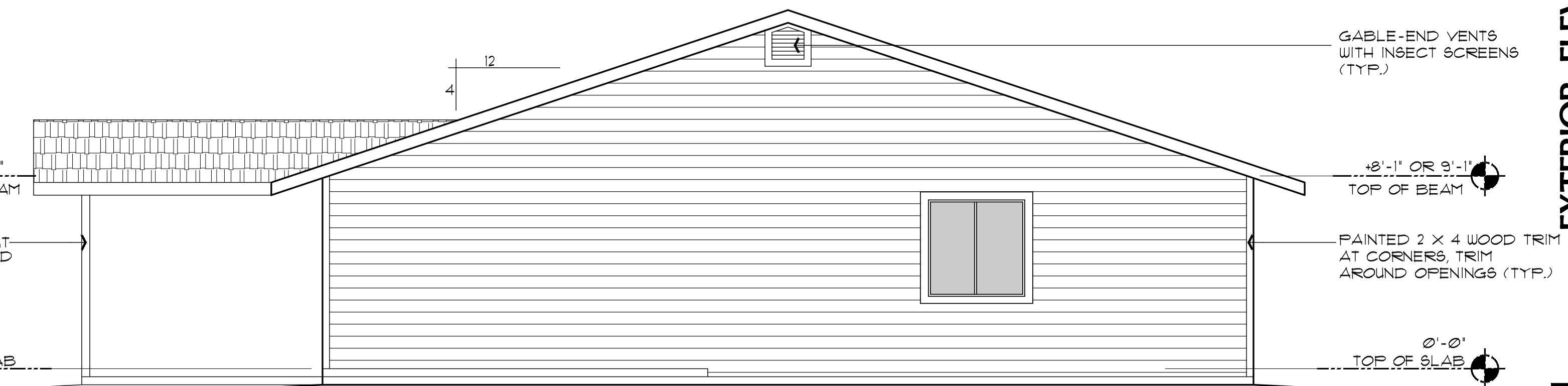

**LEFT SIDE ELEVATION (with Garage option)**

SCALE: 1/4" = 1'-0"

This design is the sole property of Mark Rogers, Architect, PLLC. Use of this design has been granted to Yavapai County Government with the drawings provided. These drawings are not to be reproduced, or copied in whole or in part, for use by any entity other than Yavapai County Government. It is only to be used for the project and site specifically identified herein and is not to be used on any other project. It is to be returned upon request.

Mark Rogers, Architect, PLLC 2026



**Mark Rogers, Architect, PLLC**

32616  
MARK F. ROGERS  
Registered Architect  
ARIZONA U.S.A.  
761 Highland Circle  
Chino Valley, Arizona 86323  
Phone: (928) 848-3516  
markrogers914@gmail.com

**EXTERIOR ELEVATIONS  
PHASE TWO - 3 BDRM / 2 BATH - LEFT PARKING**

**YAVAPAI COUNTY, ARIZONA**

1015 FAIR STREET  
PRESCOTT, ARIZONA

SHEET NO:

**A-5.0**

This design is the sole property of Mark Rogers, Architect, PLLC. Use of this design has been granted to Yavapai County Government with the drawings provided. These drawings are not to be reproduced, or copied in whole or in part, for use by any entity other than Yavapai County Government. It is only to be used for the project and site specifically identified herein and is not to be used on any other project. It is to be returned upon request.

Mark Rogers, Architect, PLLC 2026©

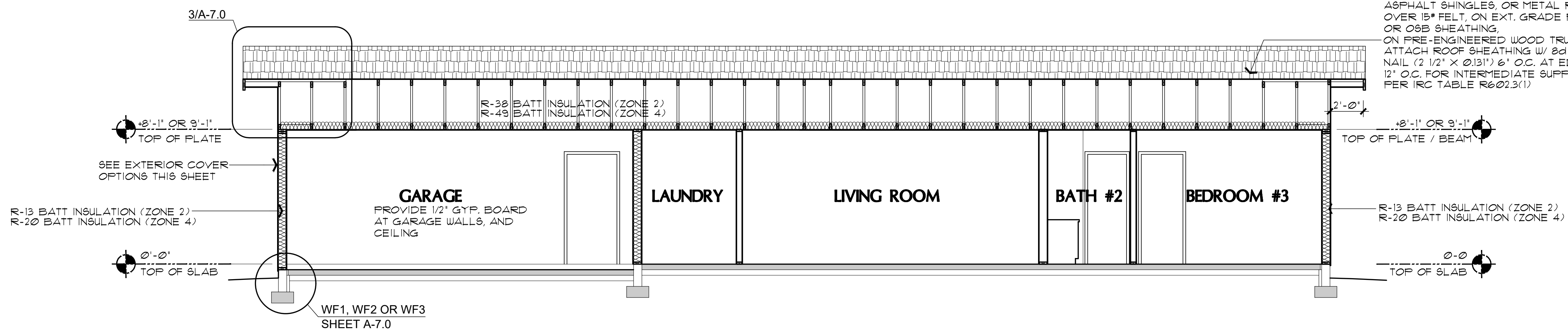
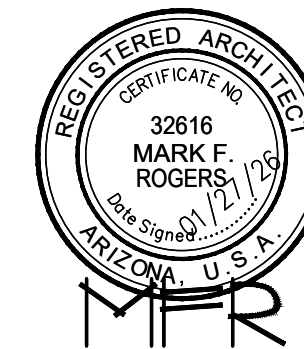

**A BUILDING CROSS SECTION**  
 SCALE: 1/4" = 1'-0"

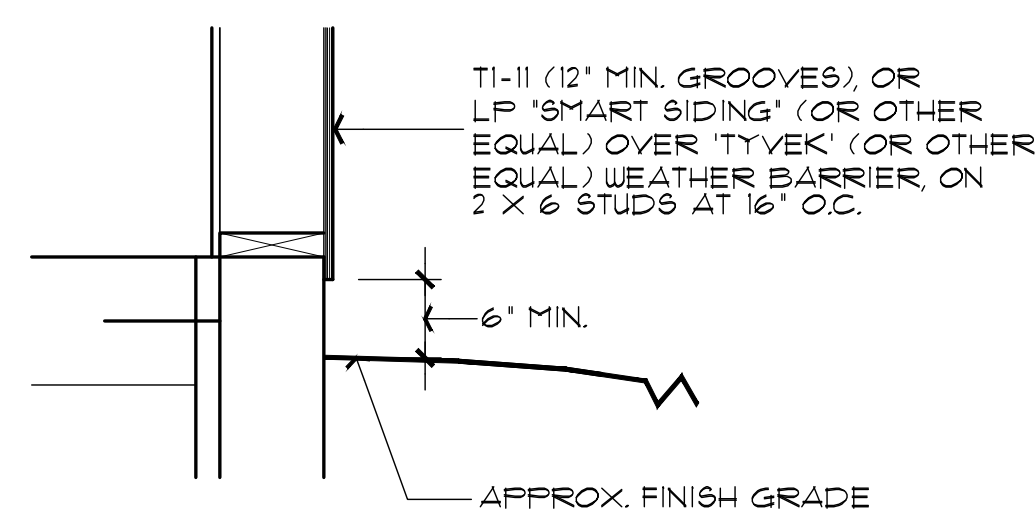

**1 T1-11, OR "SMART SIDING" OPTIONS DETAIL**  
 NO SCALE

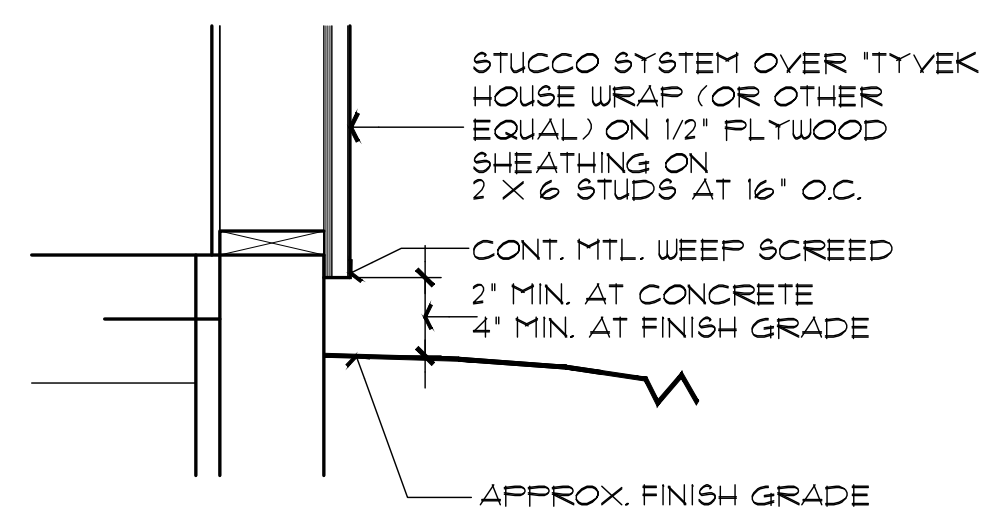

**2 STUCCO OPTION DETAIL**  
 NO SCALE

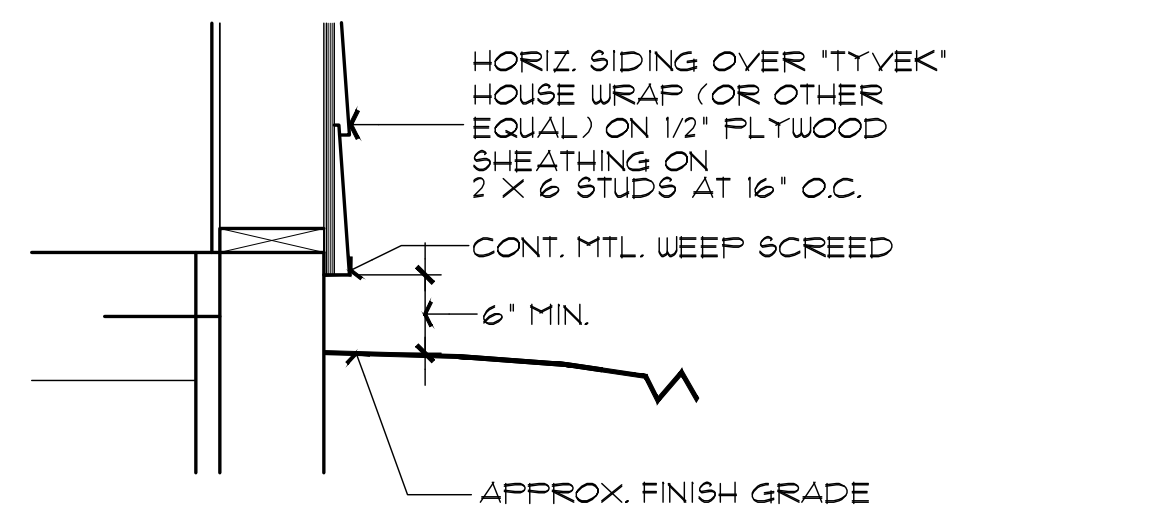

**3 HORIZ. SIDING OPTION DETAIL**  
 NO SCALE

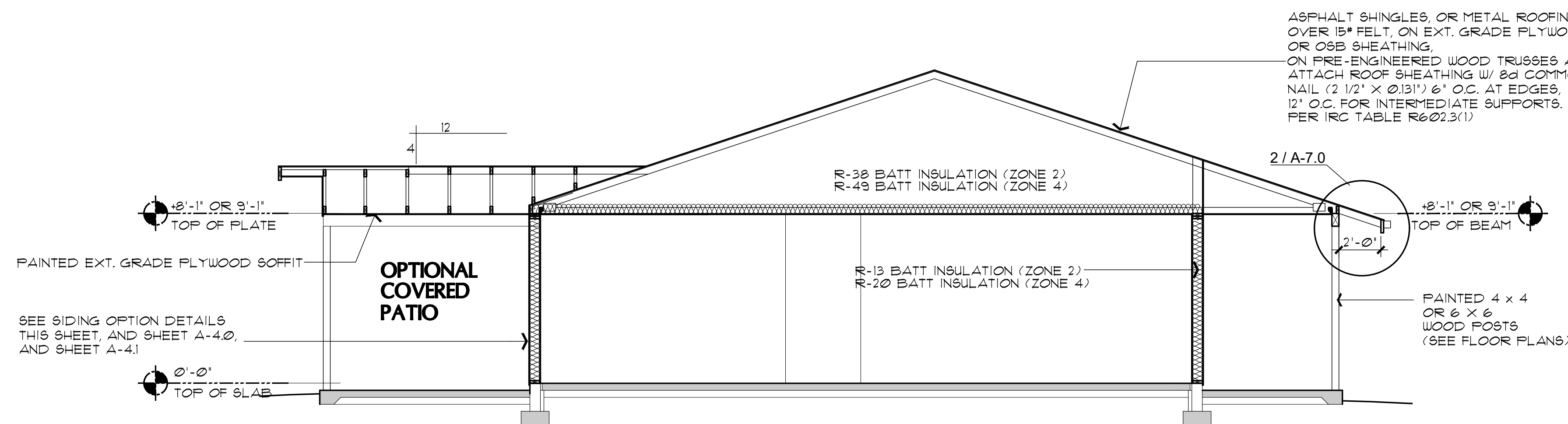

**B BUILDING CROSS SECTION**  
 SCALE: 1/4" = 1'-0"

**REVIEWED FOR DESIGN CRITERIA ONLY**

SEE ATTACHED COVER SHEET FOR ALL STAMPS. IT IS THE RESPONSIBILITY OF THE OWNER/APPLICANT TO REVIEW AND ACKNOWLEDGE APPLICABLE STAMPS.

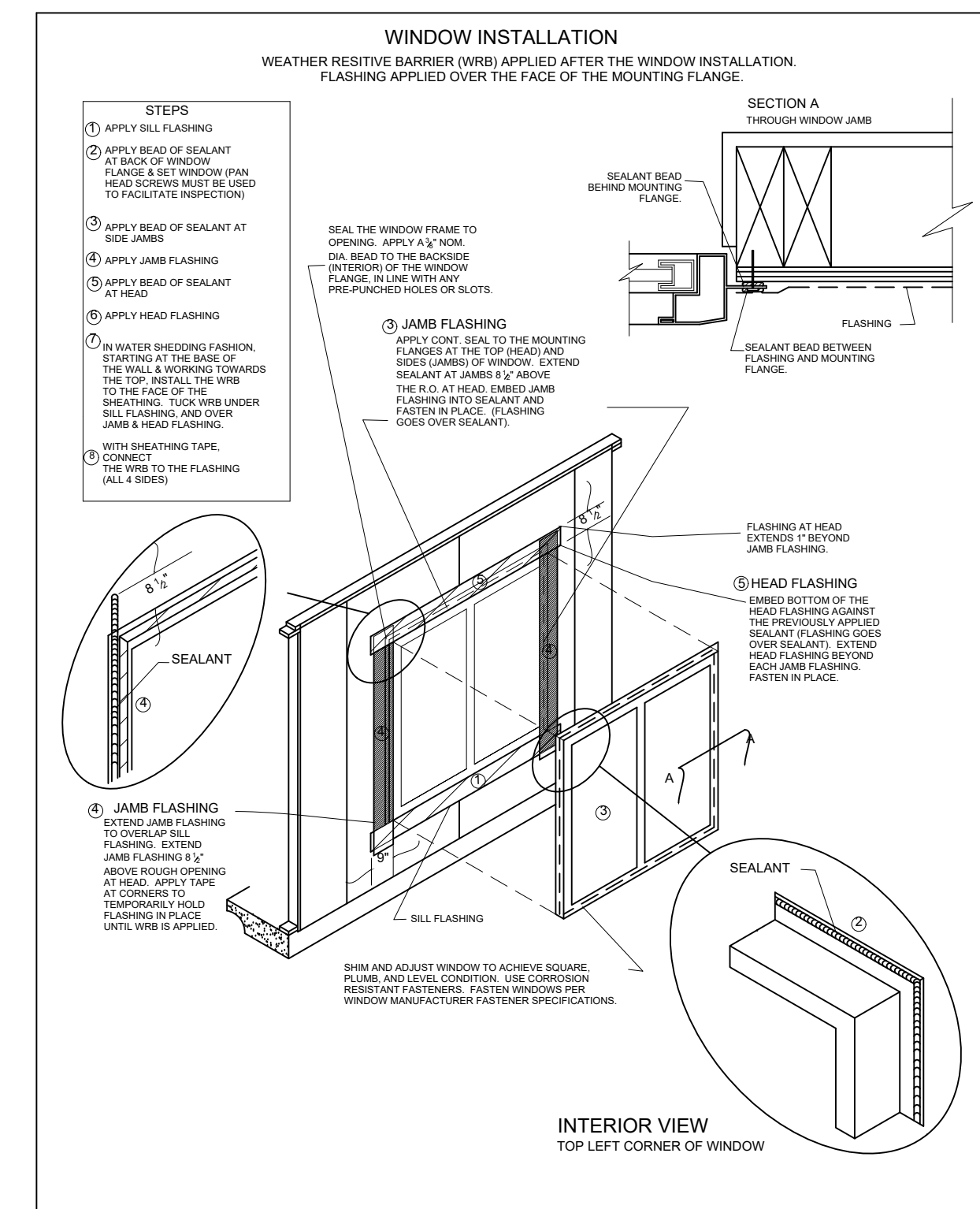

Mark Rogers, Architect, PLLC

761 Highland Circle  
 Chino Valley, Arizona 86323  
 Phone: (928) 848-3516  
 markrogers914@gmail.com

BUILDING SECTIONS  
 PHASE TWO - 3 BDRM / 2 BATH - LEFT PARKING

YAVAPAI COUNTY, ARIZONA

1015 FAIR STREET  
 PRESCOTT, ARIZONA

SHEET NO:

**A-6.0**

This design is the sole property of Mark Rogers, Architect, PLLC. Use of this design has been granted to Yavapai County Government with the drawings provided. These drawings are not to be reproduced, or copied in whole or in part, for use by any entity other than Yavapai County Government. It is only to be used for the project and site specifically identified herein and is not to be used on any other project. It is to be returned upon request.

Mark Rogers, Architect, PLLC 2026©

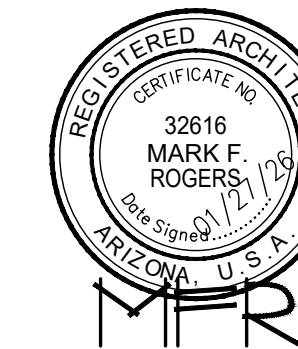

Chino Valley, Arizona 86323  
Phone: (928) 848-3516  
markrogers914@gmail.com

761 Highland Circle

1015 FAIR STREET  
PRESCOTT, ARIZONA

Mark Rogers, Architect, PLLC

FOUNDATION / ROOF DETAILS  
PHASE TWO - 3 BDRM / 2 BATH - LEFT PARKING

YAVAPAI COUNTY, ARIZONA

PROPERTY OF YAVAPAI COUNTY, AZ

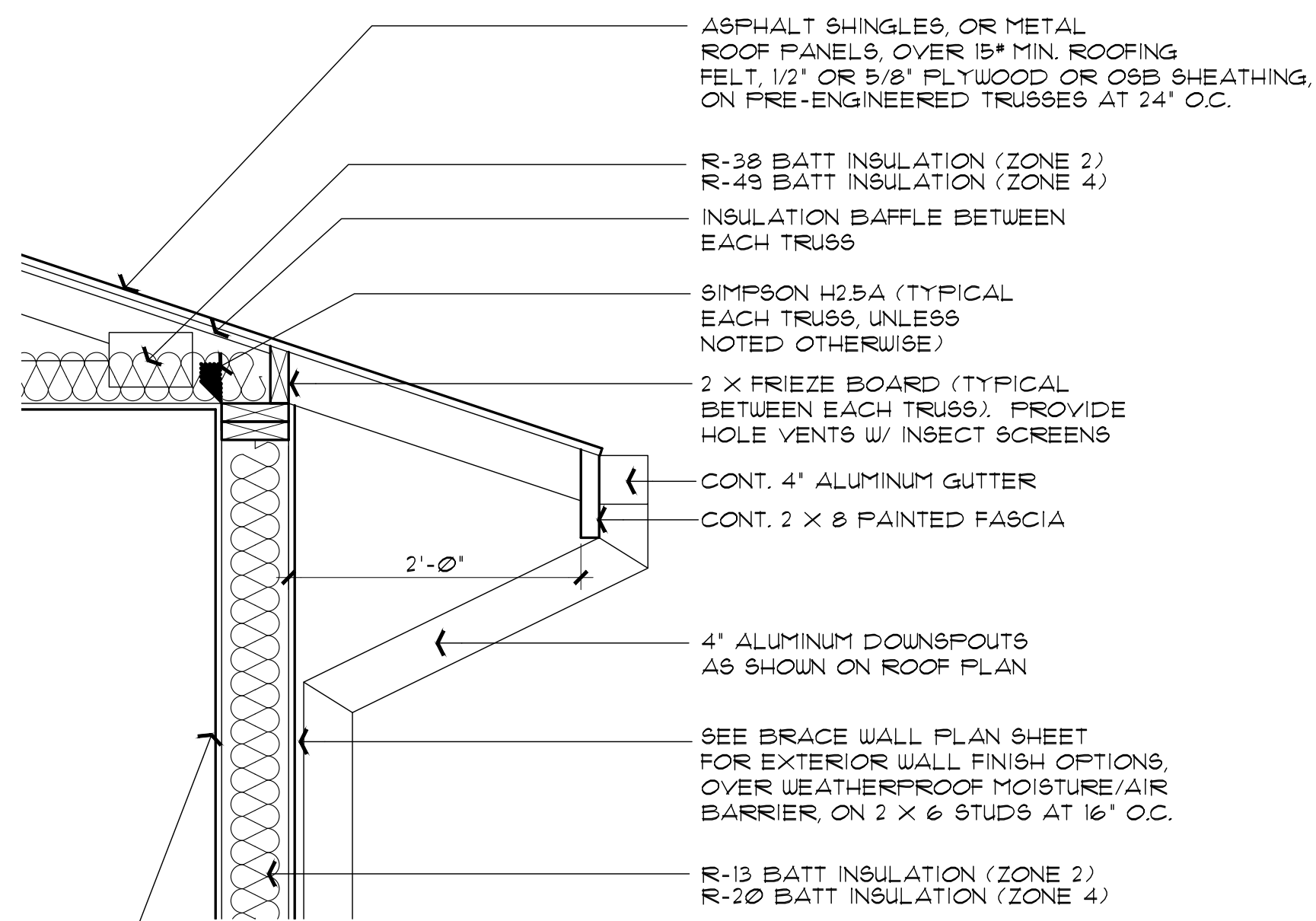

**1 ROOF OVERHANG DETAIL**

SCALE: 1" = 1'-0"

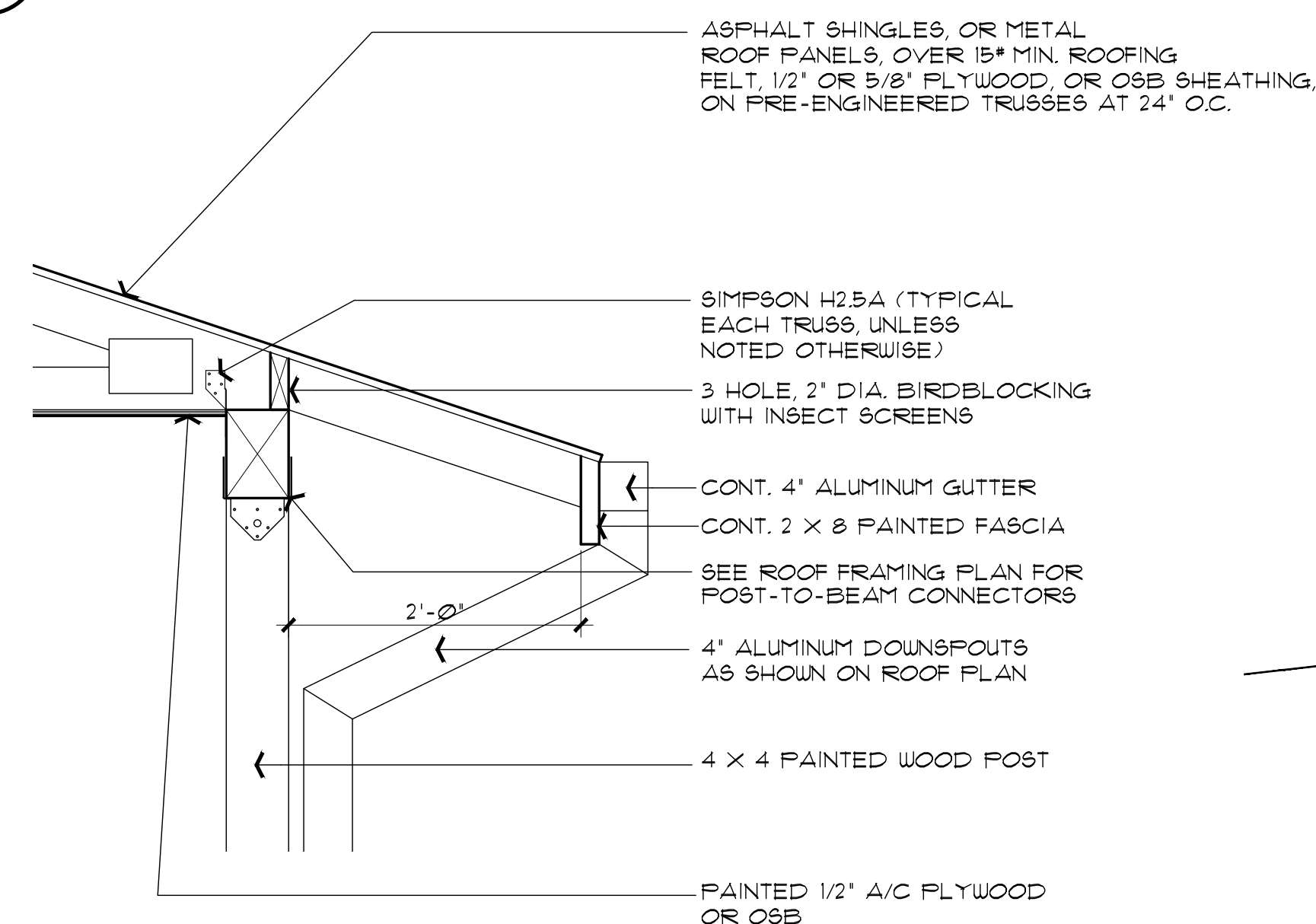

**2 ROOF OVERHANG AT BEAM DETAIL**

SCALE: 1" = 1'-0"

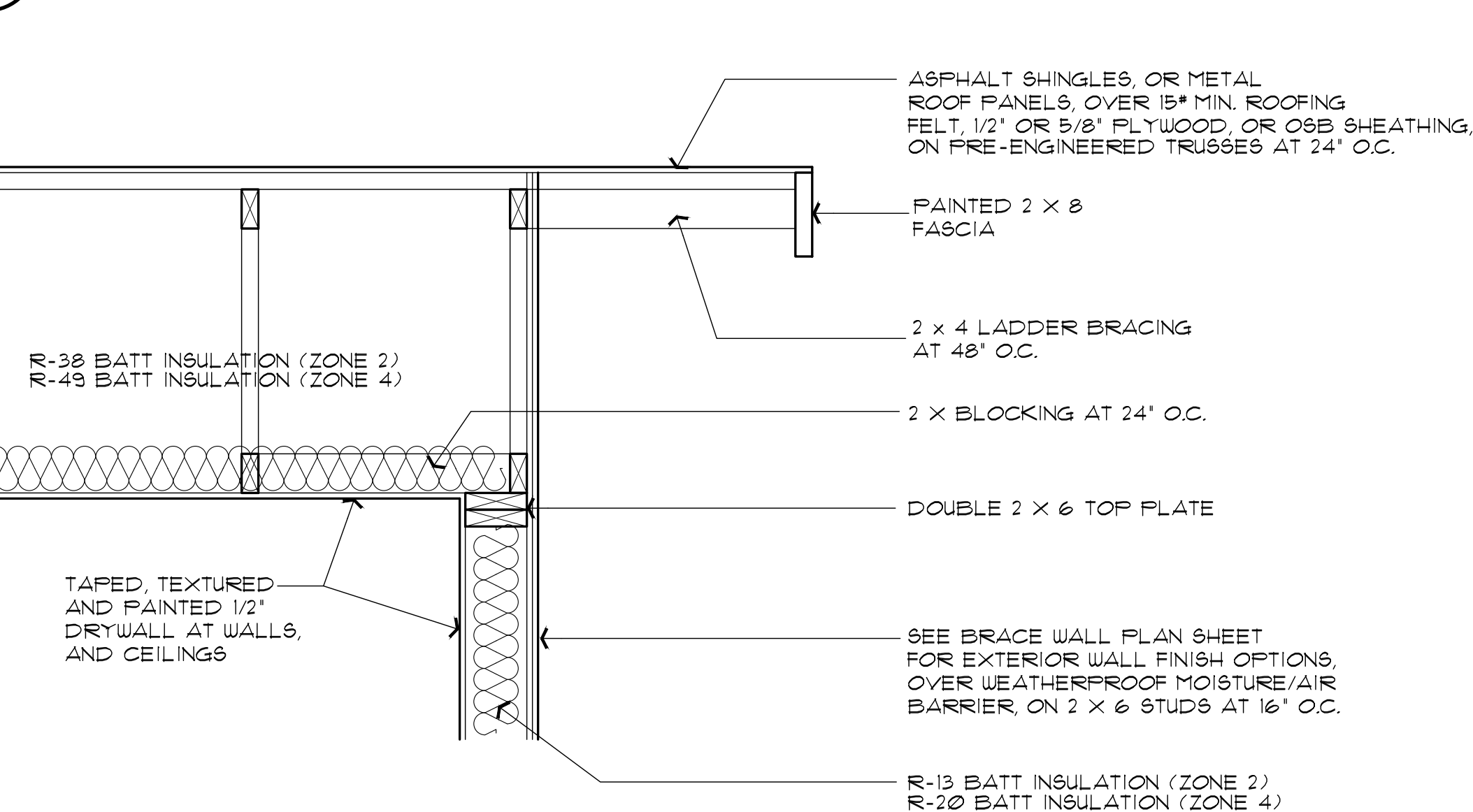

**3 GABLE END-WALL DETAIL**

SCALE: 1" = 1'-0"

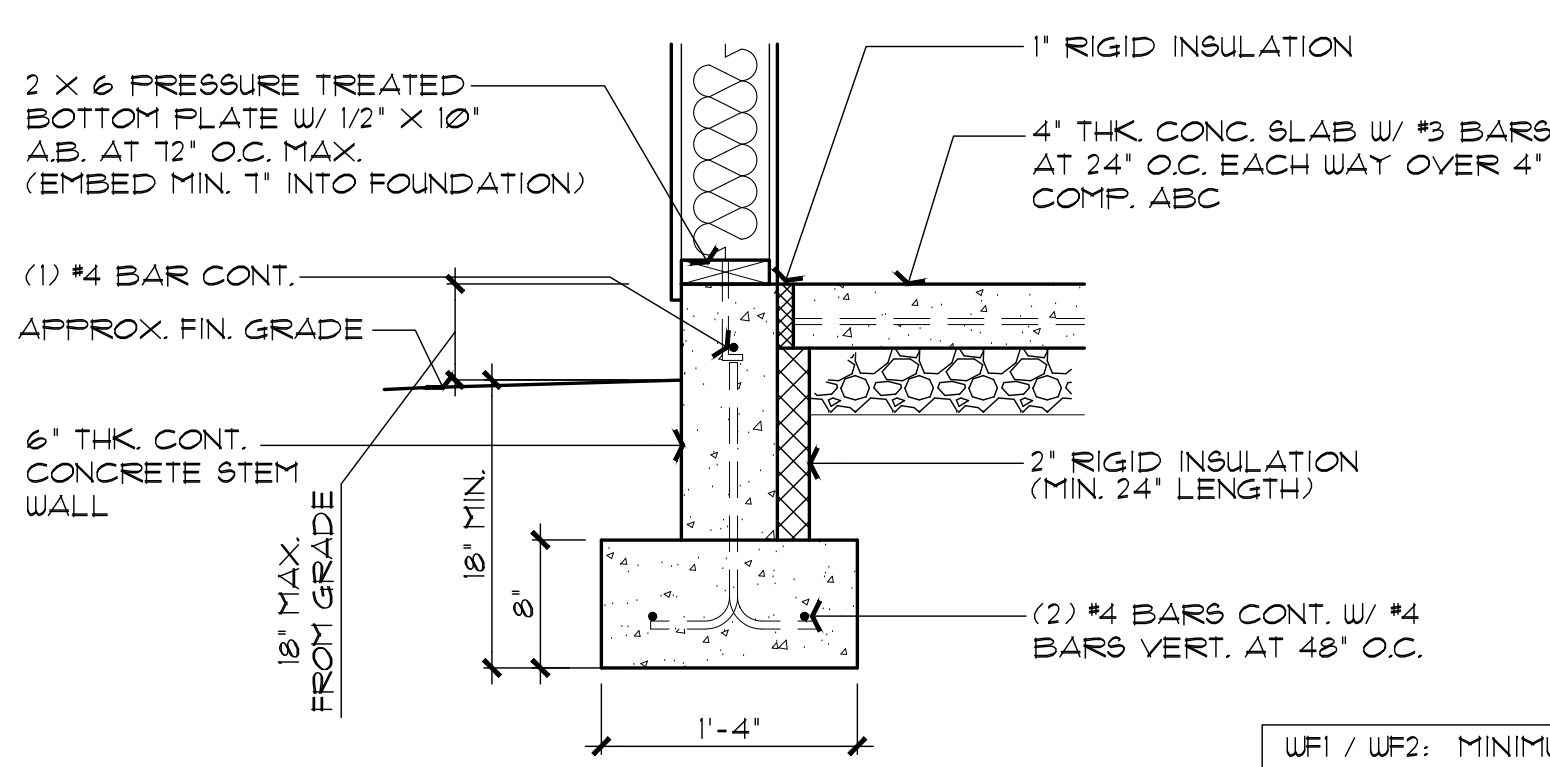

**WF1 CONCRETE STEM WALL OPTION**

SCALE: 1" = 1'-0"

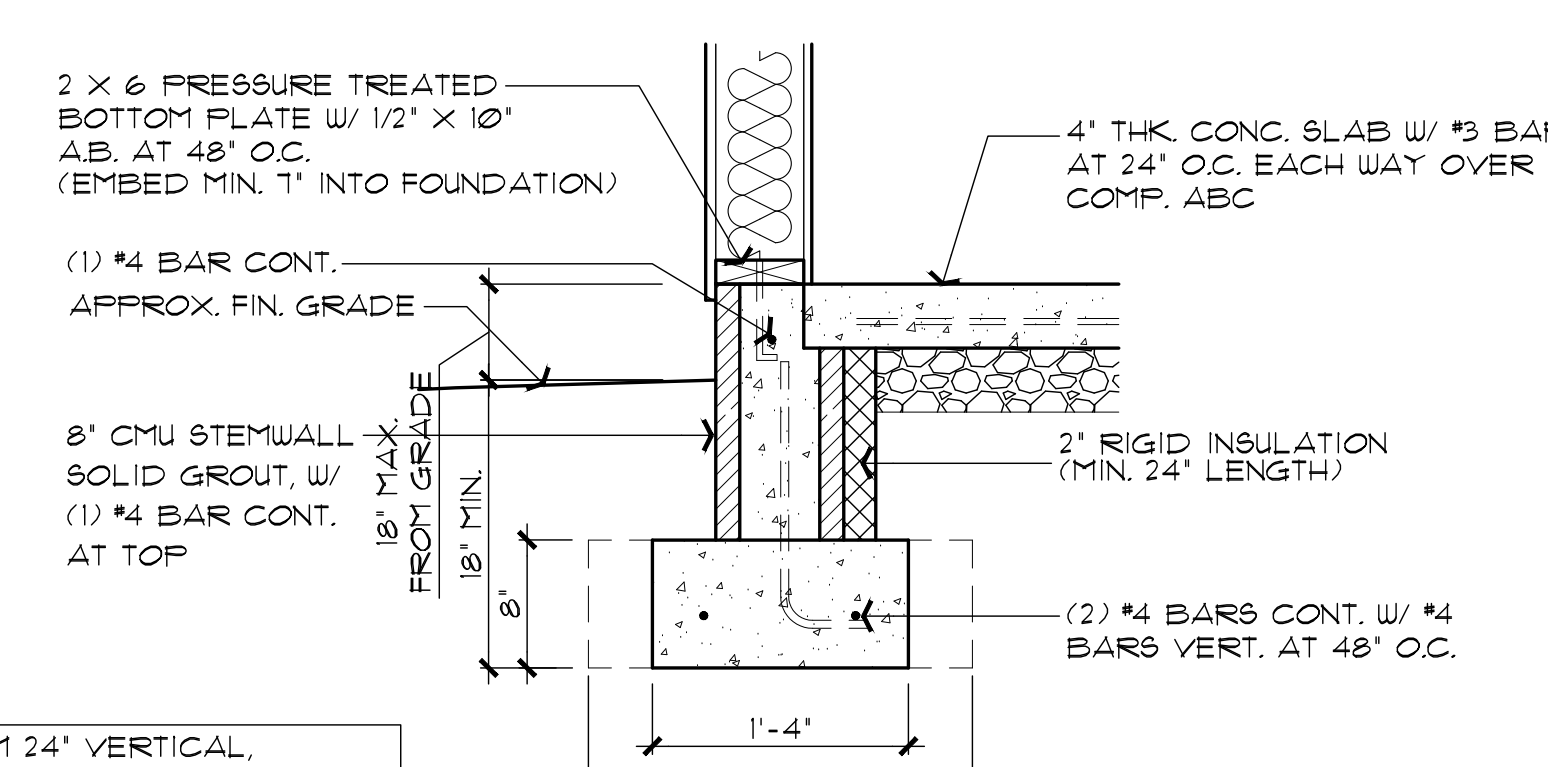

**WF2 CMU STEM WALL OPTION**

SCALE: 1" = 1'-0"

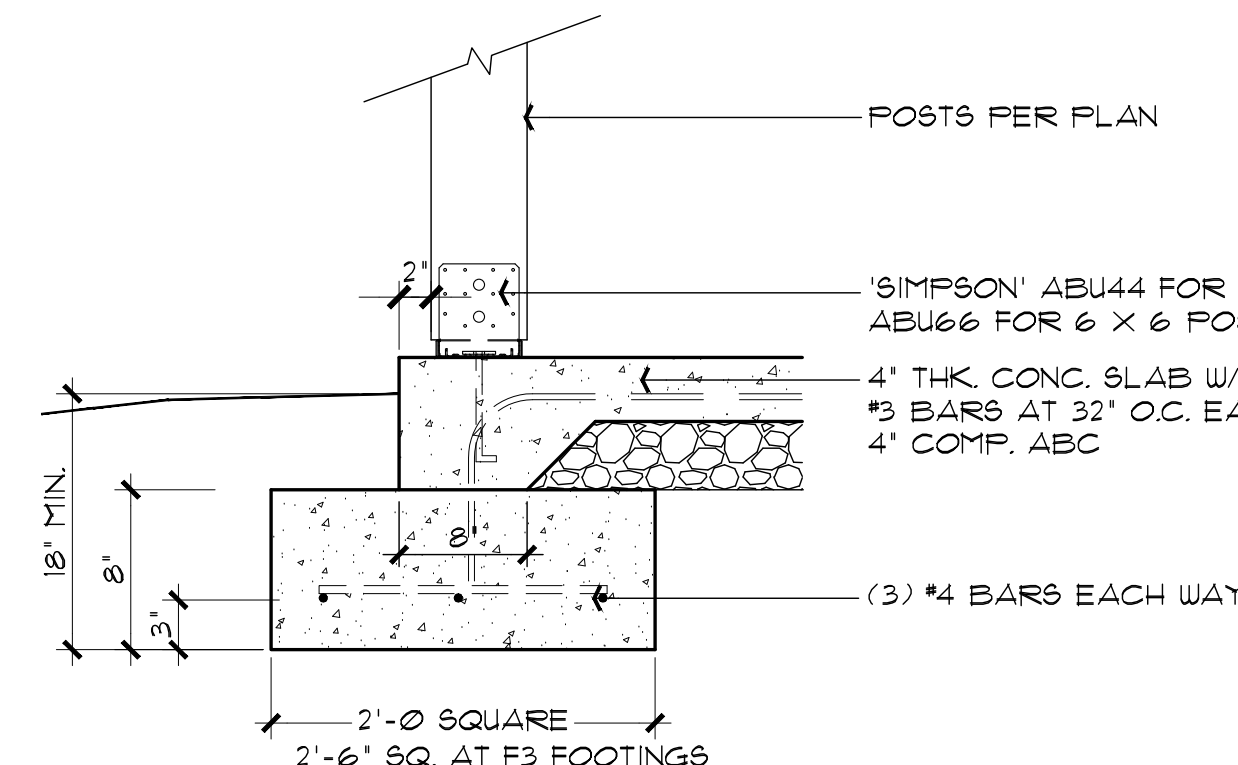

**F1/F3 POST BASE FOOTING**

SCALE: 1" = 1'-0"

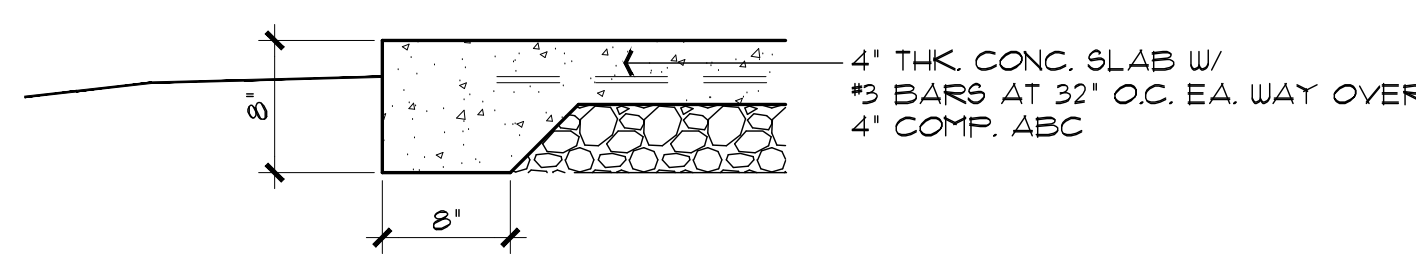

**F2 TYPICAL TURN-DOWN FOOTING**

SCALE: 1" = 1'-0"

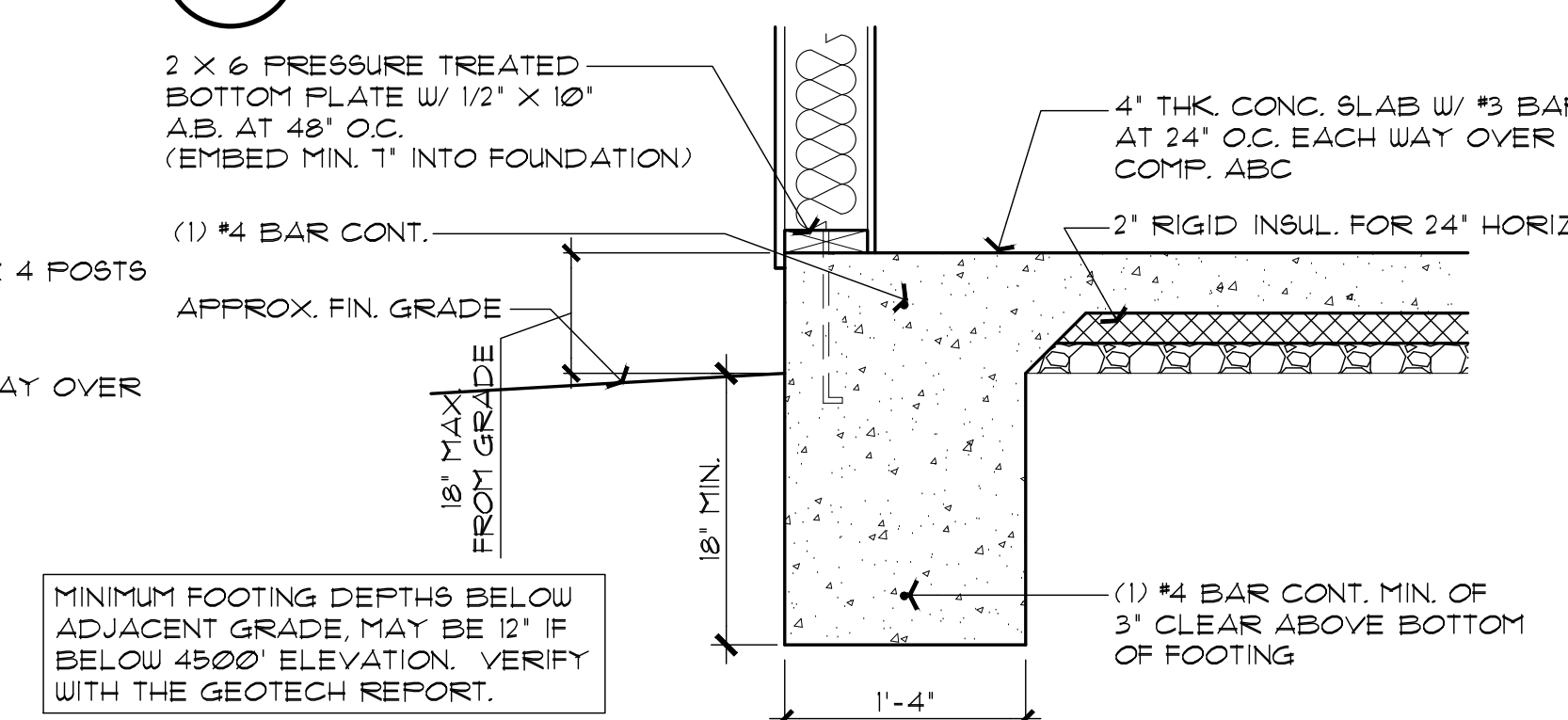

**WF3 MONOLITHIC FOOTING OPTION**

SCALE: 1" = 1'-0"

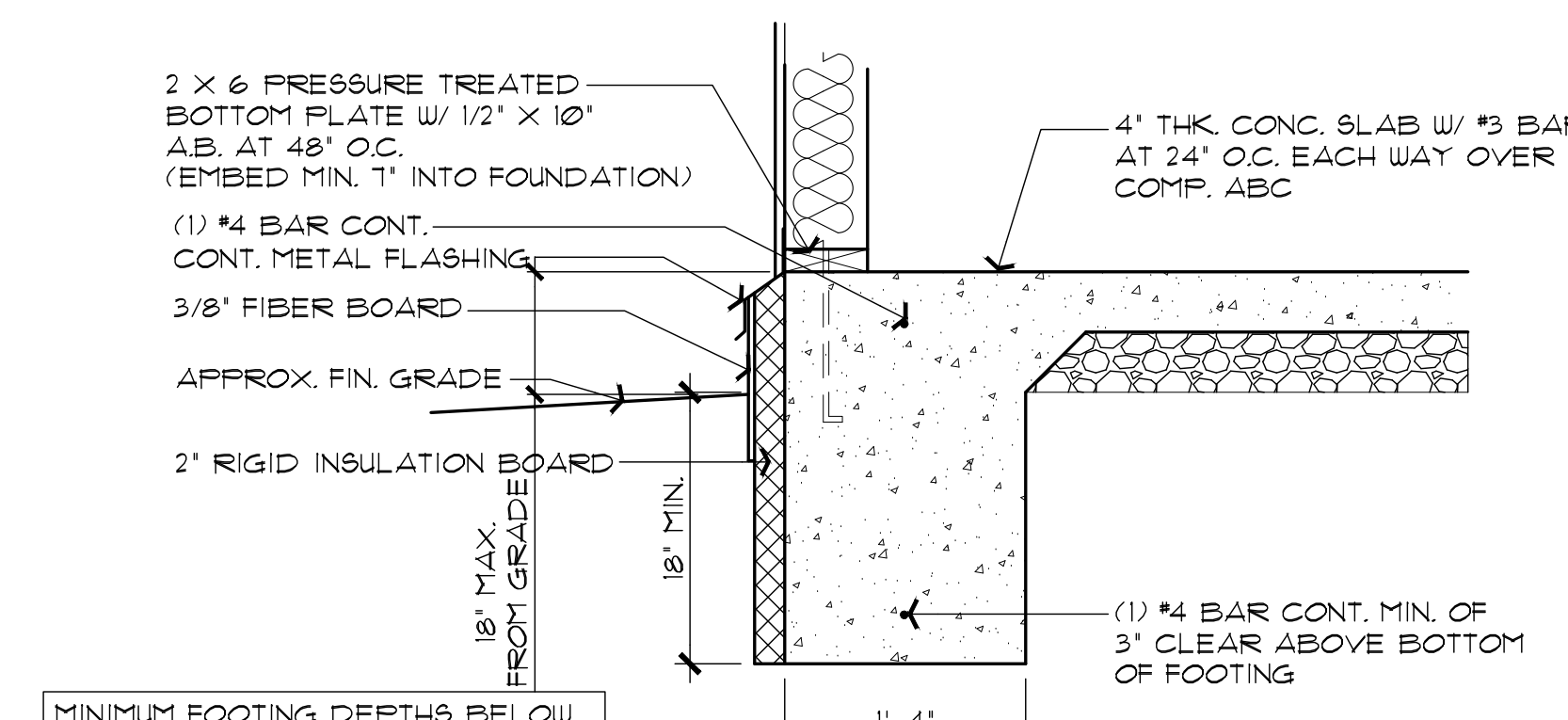

**WF4 MONOLITHIC FOOTING OPTION WITH EXTERIOR SLAB INSULATION**

SCALE: 1" = 1'-0"

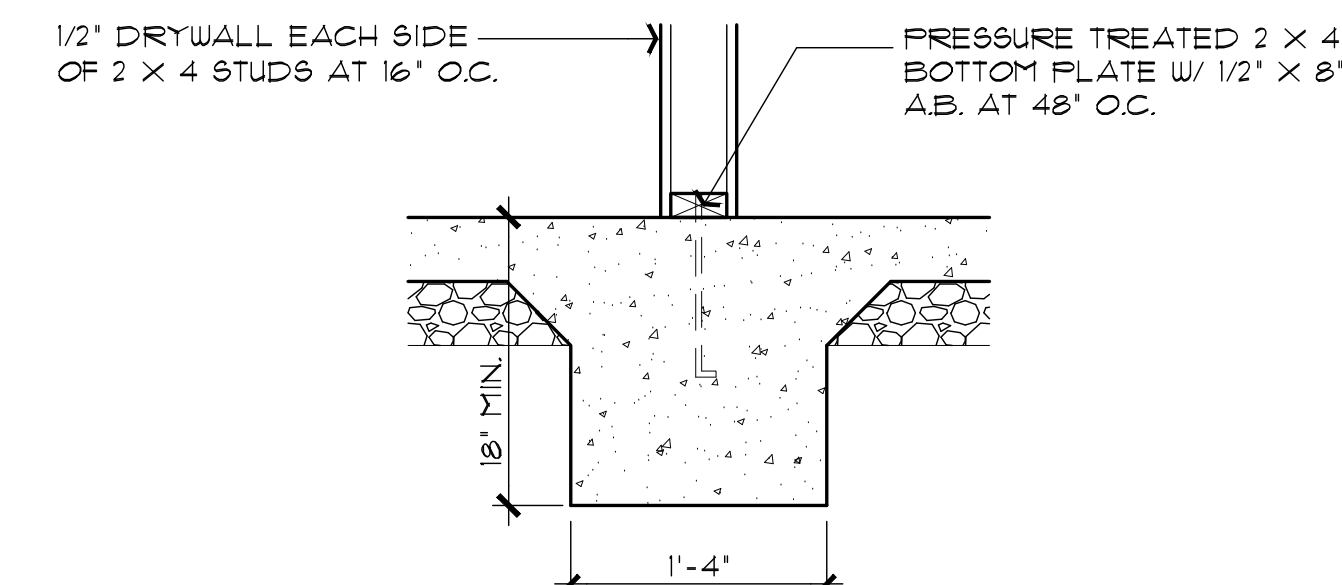

**WF5 INTERIOR FOOTING AT BRACE WALL GB METHOD (IRC TABLE R602.10.4)**

SCALE: 1" = 1'-0"

**REVIEWED FOR DESIGN CRITERIA ONLY**  
SEE ATTACHED COVER SHEET FOR ALL STAMPS. IT IS THE RESPONSIBILITY OF THE OWNER/APPLICANT TO REVIEW AND ACKNOWLEDGE APPLICABLE STAMPS.

**NOTE: SLAB INSULATION IS ONLY REQUIRED IN CLIMATE ZONE 4 (ELEVATION 3500' OR GREATER)**

PROPERTY OF YAVAPAI COUNTY, AZ

ENERGY NOTES:

- 1. WINDOWS DOOR & SKYLIGHTS
FENESTRATION U-FACTOR WINDOW AND DOORS TO BE .40 (ZONE 2) & .35 (ZONE 4) STICKER SHALL REMAIN ON WINDOWS, SKYLIGHTS & DOORS UNTIL INSPECTED AND APPROVED FOR THE ABOVE REQUIREMENT. GLAZED FENESTRATION SHGC .25 (ZONE 2) & .40 (ZONE 4)
2. CEILINGS
CEILING INSULATION TO BE MIN. R-38 (ZONE 2) & R-49 (ZONE 4) MARKERS SHALL BE AFFIXED TO THE TRUSSES OR JOIST AND MARKED WITH THE MIN. INSTALLED THICKNESS BY ONE INCH HIGH NUMBERS. A MIN. OF ONE MARKER SHALL BE INSTALLED FOR EVERY 300 SQ. FT. OF AREA WITH NUMBERS TO FACE THE ATTIC ACCESS OPENING. MARKERS MUST BE INSTALLED AT ROUGH IN OR WALL INSULATION INSPECTIONS.
3. WOOD FRAMED EXTERIOR WALLS R-13 (ZONE 2) & R-20 (ZONE 4)
WALL INSULATION SHALL BE IN SUBSTANTIAL CONTACT WITH THE SURFACE BEING INSULATED TO AVOID AIR PATHS THAT BYPASS THE INSULATION.
INSULATION SHALL NOT BE COMPRESSED BY INSET STAPLING OF THE BATT INSULATION OR OTHER MEANS
INSULATION SHALL FILL ALL CAVITIES COMPLETELY BY CUTTING INSULATION AROUND ELECTRICAL OUTLETS AND SWITCHES AND BY SLICING INSULATION TO FIT BEHIND AND IN FRONT OF ELECTRICAL WIRING IN THE CAVITY AND PLUMBING PIPING
BAND JOISTS AND OTHER INTERSTITIAL FLOOR ELEMENTS OF THE WALL SHALL BE INSULATED
4. NOT USED.
5. BUILDING THERMAL ENVELOPE
THE SEALING METHODS BETWEEN DISSIMILAR MATERIALS SHALL ALLOW FOR DIFFERENTIAL EXPANSION AND CONTRACTION. THE FOLLOWING SHALL BE CALKED, GASKETED WEATHER STRIPPED OR OTHERWISE SEALED WITH AN AIR BARRIER MATERIAL, SUITABLE FILM OR SOLID MATERIAL:
A. ALL JOINTS, SEAMS AND PENETRATIONS.
B. SITE BUILT WINDOWS, DOORS AND SKYLIGHTS
C. OPENINGS BETWEEN WINDOW AND DOOR ASSEMBLIES AND THEIR RESPECTIVE JAMBS AND FRAMING.
D. UTILITY PENETRATIONS
E. DROPPED CEILING OR CHASES ADJACENT TO THE THERMAL ENVELOPE.
F. KNEE WALLS
G. WALLS AND CEILING SEPARATING GARAGE FROM CONDITIONED SPACES.
H. BEHIND TUB AND SHOWERS ON EXTERIOR WALLS
I. COMMON WALLS BETWEEN DWELLING UNITS
J. OTHER SOURCES OF INFILTRATION.
6. FENESTRATION AIR LEAKAGE
WINDOW, SKYLIGHT AND SLIDING GLASS DOOR SHALL HAVE AN AIR INFILTRATION RATE OF NO MORE THAN 0.3 CFM PER SQUARE FOOT, AND SWINGING DOORS NO MORE THAN 0.5 CFM. SPECIFICATIONS SHALL BE LISTED ON THE MANUF. LABEL. (USE TYVEK HOUSE WRAP, INSTALL PER MANUF. SPECS)
7. RECESSED LIGHTING
RECESSED LUMINAIRES INSTALLED IN THE BUILDING THERMAL ENVELOPE SHALL BE SEALED TO LIMIT AIR LEAKAGE BETWEEN CONDITIONED AND UNCONDITIONED SPACES BY BEING:
A. IC RATED AND LABELED WITH ENCLOSURES THAT ARE SEALED OR GASKETED TO PREVENT AIR LEAKAGE TO CEILING CAVITY OR UNCONDITIONED SPACE OR
B. IC RATED AND LABELED AS MEETING ASTM E 2831 OR C. LOCATED INSIDE AIRTIGHT SEALED BOX WITH CLEARANCES OF AT LEAST 0.5 INCH FROM COMBUSTIBLE MATERIAL AND 3 INCHES FROM INSULATION.
8. HEAT PUMP SUPPLEMENTARY HEAT
HEAT PUMPS HAVING SUPPLEMENTARY ELECTRIC- RESISTANCE HEAT SHALL HAVE CONTROLS THAT, EXCEPT DURING DEFROST PREVENT SUPPLEMENTAL HEAT OPERATION WHEN THE HEAT PUMP COMPRESSOR CAN MEET THE HEATING LOAD.
9. CONTROLS
AT LEAST ONE THERMOSTAT SHALL BE PROVIDED FOR EACH SEPARATE HEATING & COOLING SYSTEM.
10. DUCT INSULATION
SUPPLY AND RETURN DUCTS SHALL BE INSULATED TO A MIN. OF R-8 (EXCEPT DUCTS THAT COMPLETELY INSIDE THE BUILDING THERMAL ENVELOPE)
11. SEALING
ALL DUCTS, AIR HANDLERS, FILTER BOXES, AND BUILDING CAVITIES (NOT FOR AIR SUPPLY) USED AS DUCTS SHALL BE SEALED. JOINTS AND SEAMS SHALL COMPLY WITH SECTION M1601.3.1 OF THE IRC.
12. MECHANICAL SYSTEM PIPING INSULATION
MECHANICAL SYSTEM PIPING CAPABLE OF CARRYING FLUIDS ABOVE 105 D. F OR BELOW 55 D. F SHALL BE INSULATED TO A MIN. OF R-3
13. CIRCULATING HOT WATER SYSTEMS
ALL CIRCULATING SERVICE HOT WATER PIPING SHALL BE INSULATED TO AT LEAST R-3. ALL NEW RESIDENCES WITH 2 OR MORE BATHROOMS SHALL HAVE A CIRCULATING HOT WATER SYSTEM. THIS SHALL INCLUDE AN AUTOMATIC OR READILY ACCESSIBLE MANUAL SWITCH THAT CAN TURN OFF THE HWCP WHEN THE SYSTEM IS NOT IN USE. THERMAL SIPHONING SYSTEMS SHALL HAVE A VALVE TO REDUCE FLOW. ALTERNATE SYSTEM SHALL BE CONSIDERED.
14. MECHANICAL VENTILATION
OUTDOOR AIR INTAKES AND EXHAUST SHALL HAVE AUTOMATIC GRAVITY DAMPER THAT CLOSE WHEN THE VENTILATION SYSTEM IS NOT OPERATING.
15. EQUIPMENT SIZING
HEATING & COOLING EQUIPMENT SHALL BE SIZED IN ACCORDANCE WITH SECTION M1401.3 OF THE IRC.
16. AIR LEAKAGE
AIR FLOW RETARDERS (HOUSE WRAPS) MUST BE:
A. IMPERMEABLE TO AIR FLOW.
B. CONTINUOUS OVER THE ENTIRE BUILDING ENVELOPE
C. ABLE TO WITHSTAND THE FORCES THAT MAY ACT ON IT DURING AND AFTER CONSTRUCTION.
D. DURABLE OVER THE EXPECTED LIFETIME OF THE BUILDING.
E. ALL SEAMS AND EDGES MUST BE SEALED/TAPED PER MANUF. SPECIFICATIONS

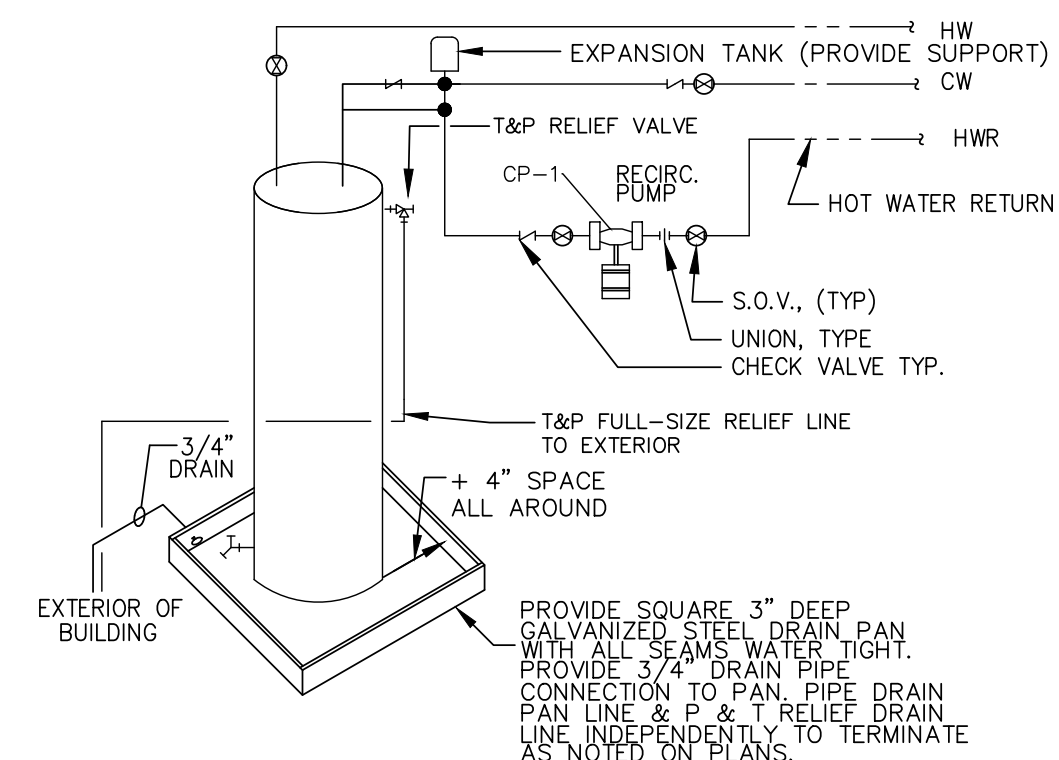

PROVIDE ACCESSIBLE ELECTRICAL DISCONNECT ELECTRIC WATER HEATER

NO SCALE

NOTE: DRAIN PAN, AND T&P MUST DRAIN BY GRAVITY. WATER HEATER SHALL BE HIGH ENOUGH OFF THE FLOOR TO PROVIDE FOR DISCHARGE PIPING TO EXTERIOR.

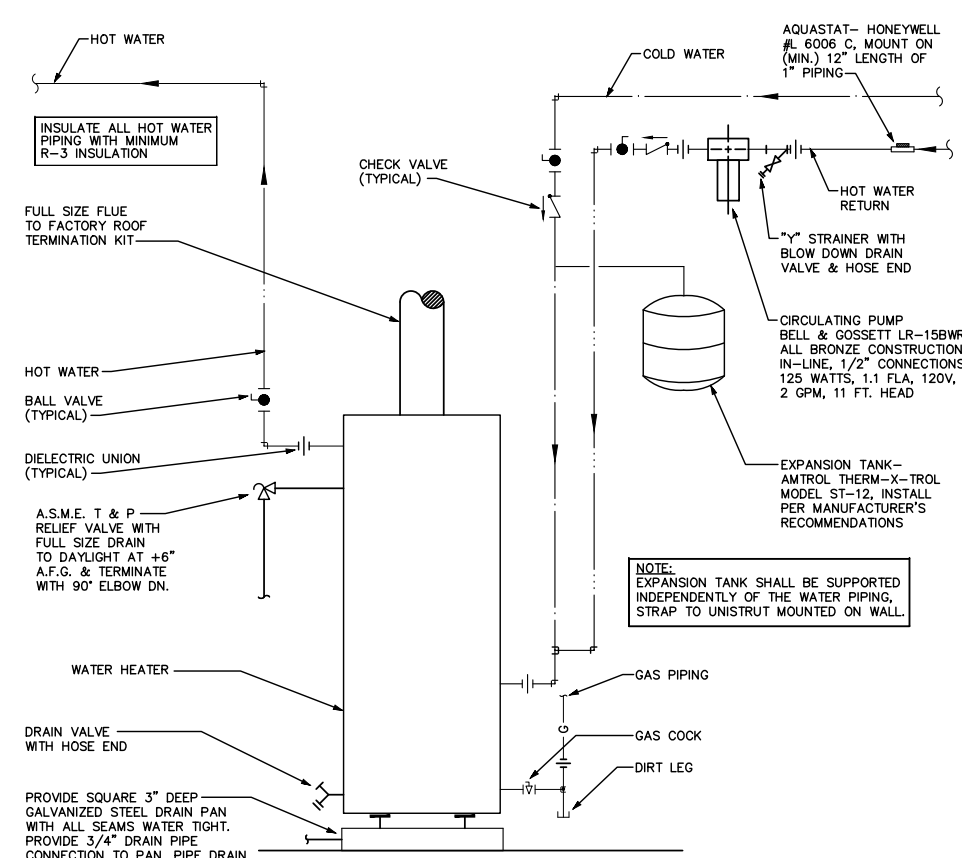

GAS WATER HEATER OPTION

NO SCALE

REVIEWED FOR DESIGN CRITERIA ONLY
SEE ATTACHED COVER SHEET FOR ALL STAMPS. IT IS THE RESPONSIBILITY OF THE OWNER/APPLICANT TO REVIEW AND ACKNOWLEDGE APPLICABLE STAMPS.

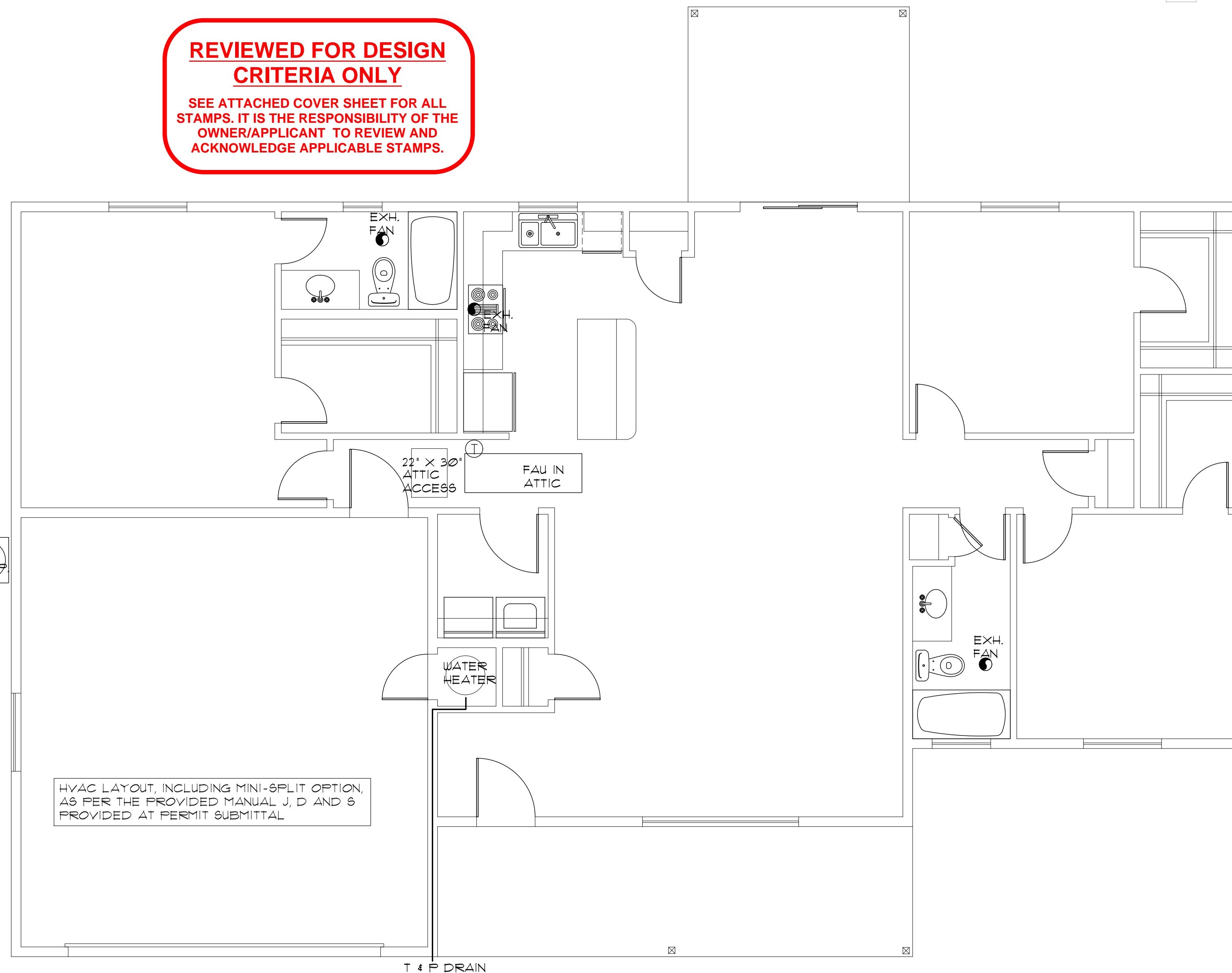

HVAC LAYOUT, INCLUDING MINI-SPLIT OPTION, AS PER THE PROVIDED MANUAL J, D AND S PROVIDED AT PERMIT SUBMITTAL

HVAC PLAN

SCALE: 1/4" = 1'-0"

- Supply-Air Grill
Return Air Grill
Thermostat

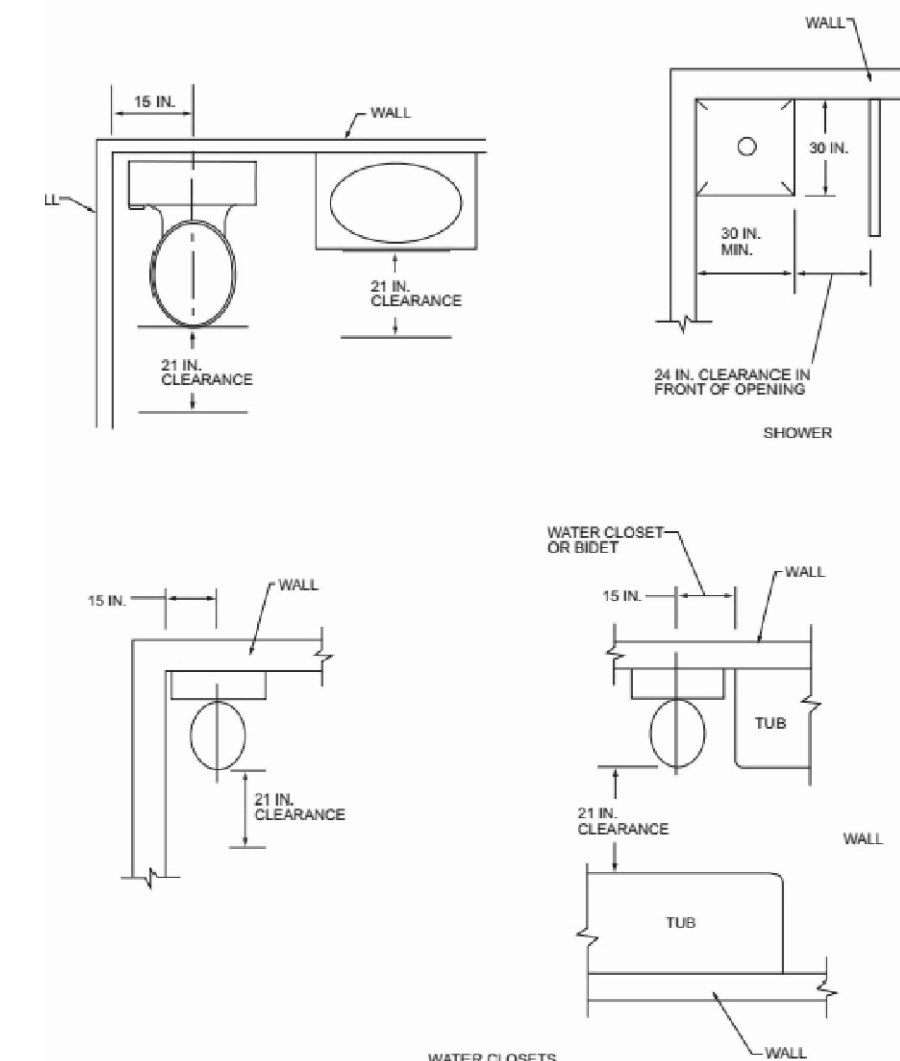

PLUMBING FIXTURE CLEARANCES

NO SCALE

PER IRC FIGURE R321.1

HVAC/PLUMBING GENERAL NOTES:

- 1. THE MECHANICAL CONTRACTOR SHALL DETERMINE THE FINAL EQUIPMENT SIZING, DUCT SIZING, AND DUCT LAYOUT PRIOR TO INSTALLATION.
2. DRAIN AND VENT SIZES TO BE DETERMINED BY PLUMBING CONTRACTOR.
3. WATER HEATER RELIEF VALVE SHALL EXTEND OUTSIDE OF THE BUILDING WITH THE END OF THE PIPE NOT MORE THAN 2' NOR LESS THAN 6' ABOVE THE GROUND AND POINTING DOWNWARD.
4. PROVIDE A FAN, AND DRAIN FOR THE WATER HEATER.
5. THE CLOTHES DRYER EXHAUST DUCT SHALL BE AT LEAST THE DIAMETER OF THE APPLIANCE OUTLET AS RECOMMENDED BY THE MANUFACTURER AND SHALL TERMINATE AT THE EXTERIOR OF THE BUILDING. IT SHALL NOT EXCEED 25' IN LENGTH WITH REDUCTIONS FOR BENDS. THE DUCT SHALL TERMINATE NOT LESS THAN 3' FROM A PROPERTY LINE.
6. THE SITE PLAN SHALL INDICATE THE LOCATION OF THE GAS SOURCE, THE DISTANCE AND PIPE SIZE FROM THE SOURCE, TO THE RESIDENCE, AND THE TYPE OF FUEL (NATURAL GAS OR PROPANE).

- 1. DOOR AT WATER HEATER CLOSET SHALL BE LOUVERED FOR COMBUSTION AIR (MIN. REQUIREMENTS OF 100 SQ. INCHES OF FREE AIR).

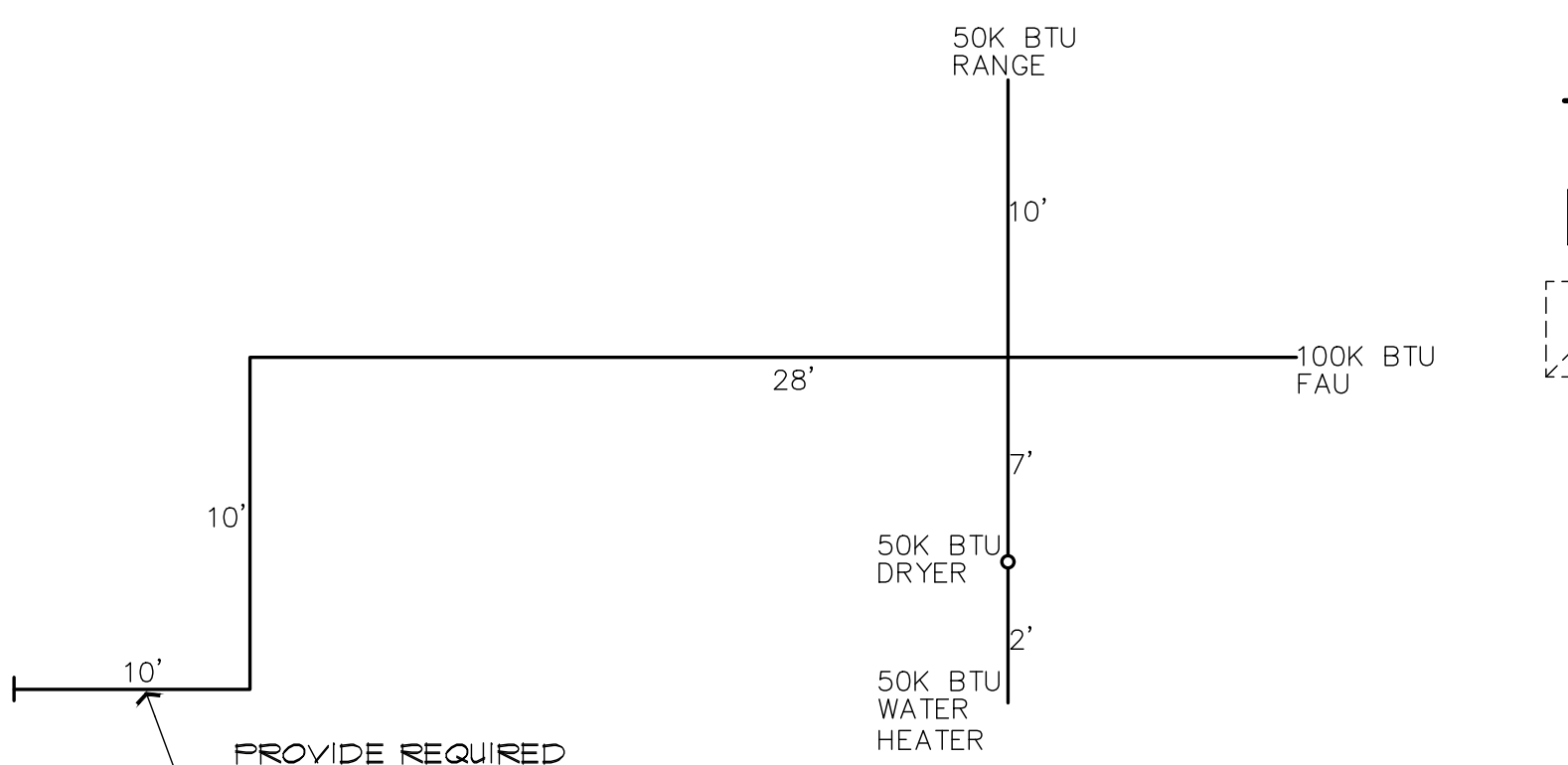

GAS PIPING ISOMETRIC

NO SCALE

NOTE: USE 1" DIA. PIPING FOR ALL FLOOR PLAN LAYOUTS. LONGEST LENGTH METHOD G2413.4(1) TABLE G2413.4(1) 250K TOTAL BTU LOAD USE THE '10' TOTAL LENGTH USE 1" DIA. PIPING

THE PLUMBING CONTRACTOR SHALL VERIFY ALL SIZING, AND FITTINGS, PRIOR TO INSTALLATION.

NOTE: EXACT LENGTH FROM EXTERIOR OF STRUCTURE, TO GAS SOURCE, WILL VARY FOR EACH PROJECT. A REVISED GAS ISOMETRIC WILL BE REQUIRED IF THE LOCATION OF THE LP/NG SOURCE EXCEEDS 10' FROM THE STRUCTURE

HVAC PLAN (FAU above habitable area) ENERGY NOTES / DETAILS PHASE TWO - 3 BDRM / 2 BATH - LEFT PARKING

YAVAPAI COUNTY, ARIZONA

1015 FAIR STREET PRESCOTT, ARIZONA

Mark Rogers, Architect, PLLC

761 Highland Circle Chino Valley, Arizona 86323 Phone: (928) 848-3516 markrogers914@gmail.com



Mark Rogers, Architect, PLLC 2026
This design is the sole property of Mark Rogers, Architect, PLLC. Use of this design has been granted to Yavapai County Government with the drawings provided. These drawings are not to be reproduced, or copied in whole or in part, for use by any entity other than Yavapai County Government. It is only to be used for the project and site specifically identified herein and is not to be used on any other project. It is to be returned upon request.

This design is the sole property of Mark Rogers, Architect, PLLC. Use of this design has been granted to Yavapai County Government with the drawings provided. These drawings are not to be reproduced, or copied in whole or in part, for use by any entity other than Yavapai County Government. It is only to be used for the project and site specifically identified herein and is not to be used on any other project. It is to be returned upon request.

Mark Rogers, Architect, PLLC 2026©



Mark Rogers, Architect, PLLC

761 Highland Circle  
 ♦♦ Chino Valley, Arizona 86323  
 Phone: (928) 848-3516  
 markrogers914@gmail.com

PROPERTY OF YAVAPAI COUNTY, AZ

HVAC PLAN (FAU above Garage/Carport)  
 ENERGY NOTES / DETAILS  
 PHASE TWO - 3 BDRM / 2 BATH - LEFT PARKING

YAVAPAI COUNTY, ARIZONA

1015 FAIR STREET  
 PRESCOTT, ARIZONA

**REVIEWED FOR DESIGN CRITERIA ONLY**  
 SEE ATTACHED COVER SHEET FOR ALL STAMPS. IT IS THE RESPONSIBILITY OF THE OWNER/APPLICANT TO REVIEW AND ACKNOWLEDGE APPLICABLE STAMPS.

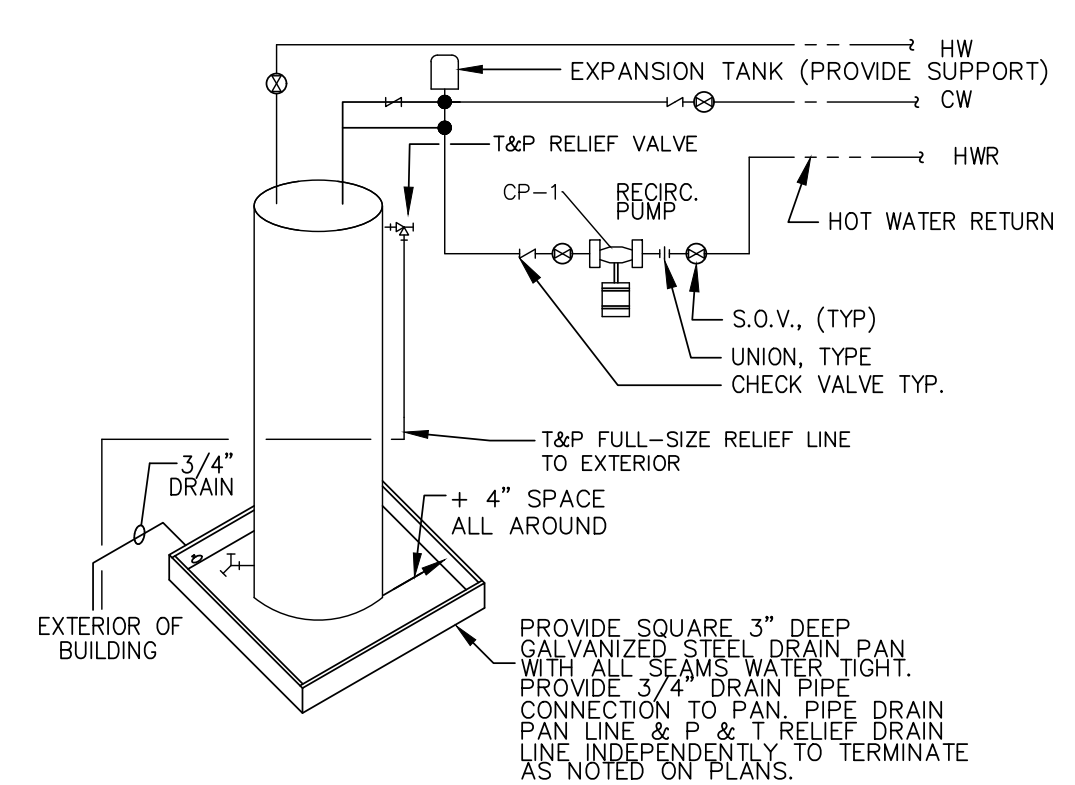

**PROVIDE ACCESSIBLE ELECTRICAL DISCONNECT**

**ELECTRIC WATER HEATER**

NO SCALE

NOTE: DRAIN PAN, AND T&P MUST DRAIN BY GRAVITY. WATER HEATER SHALL BE HIGH ENOUGH OFF THE FLOOR TO PROVIDE FOR DISCHARGE PIPING TO EXTERIOR.

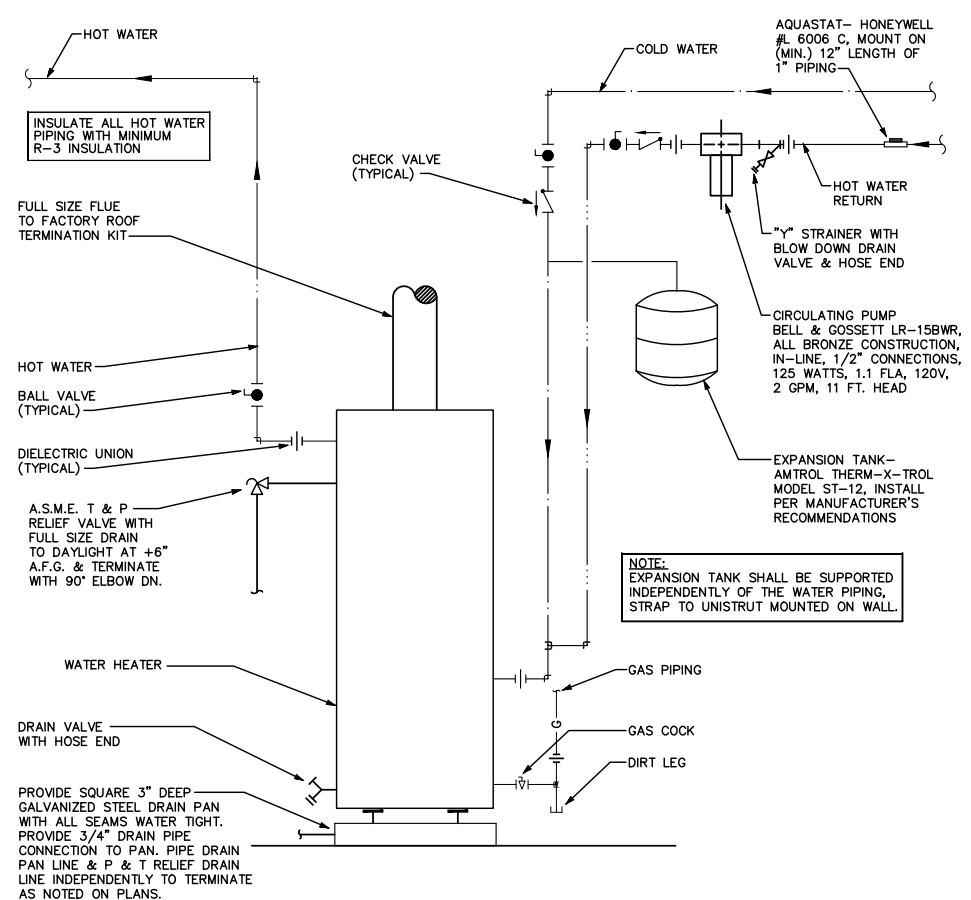

**GAS WATER HEATER OPTION**

NO SCALE

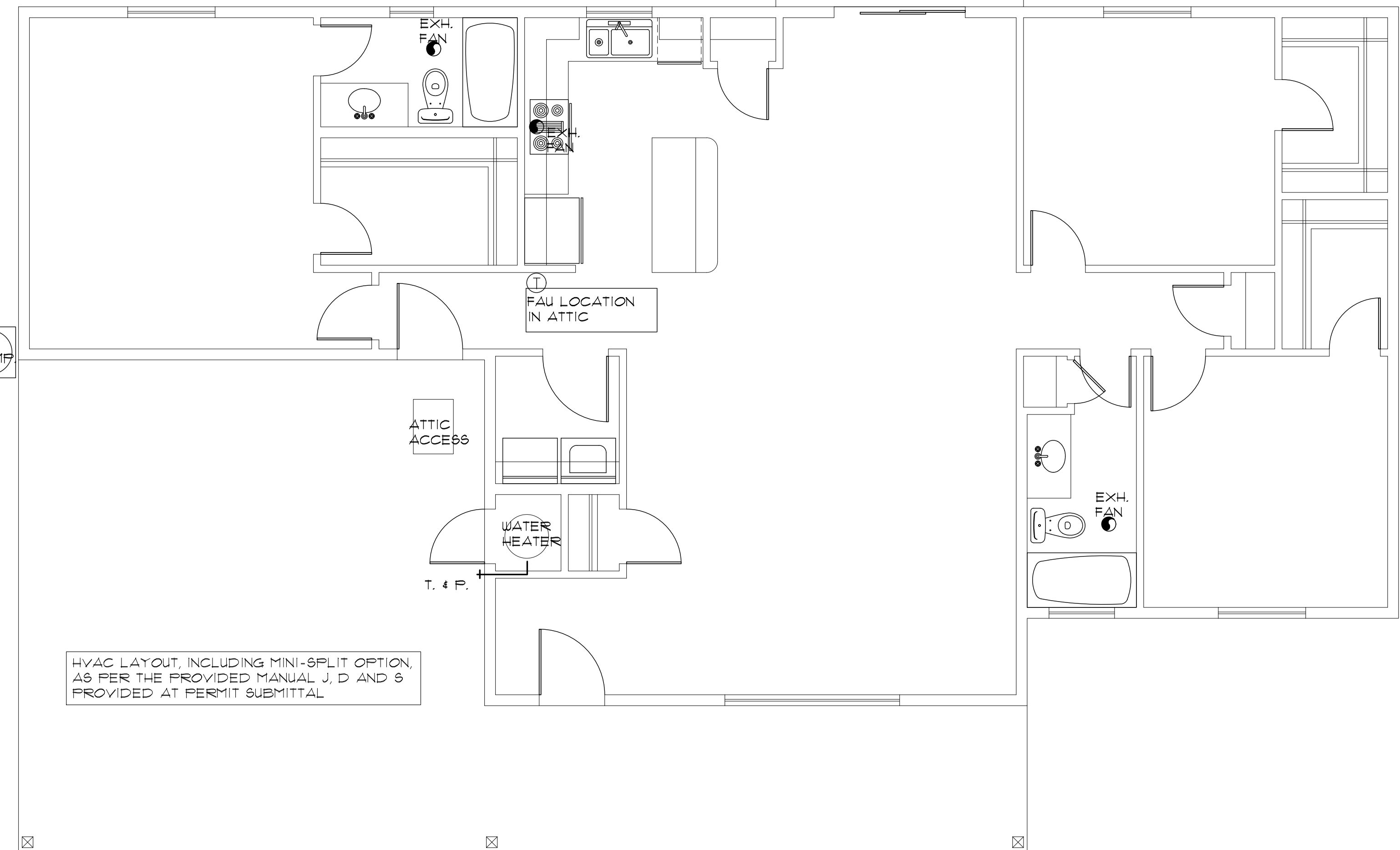

**HVAC PLAN (with Carport option)**

SCALE: 1/4" = 1'-0"

- ☒ SUPPLY-AIR GRILL
- ☒ RETURN AIR GRILL
- Ⓢ THERMOSTAT

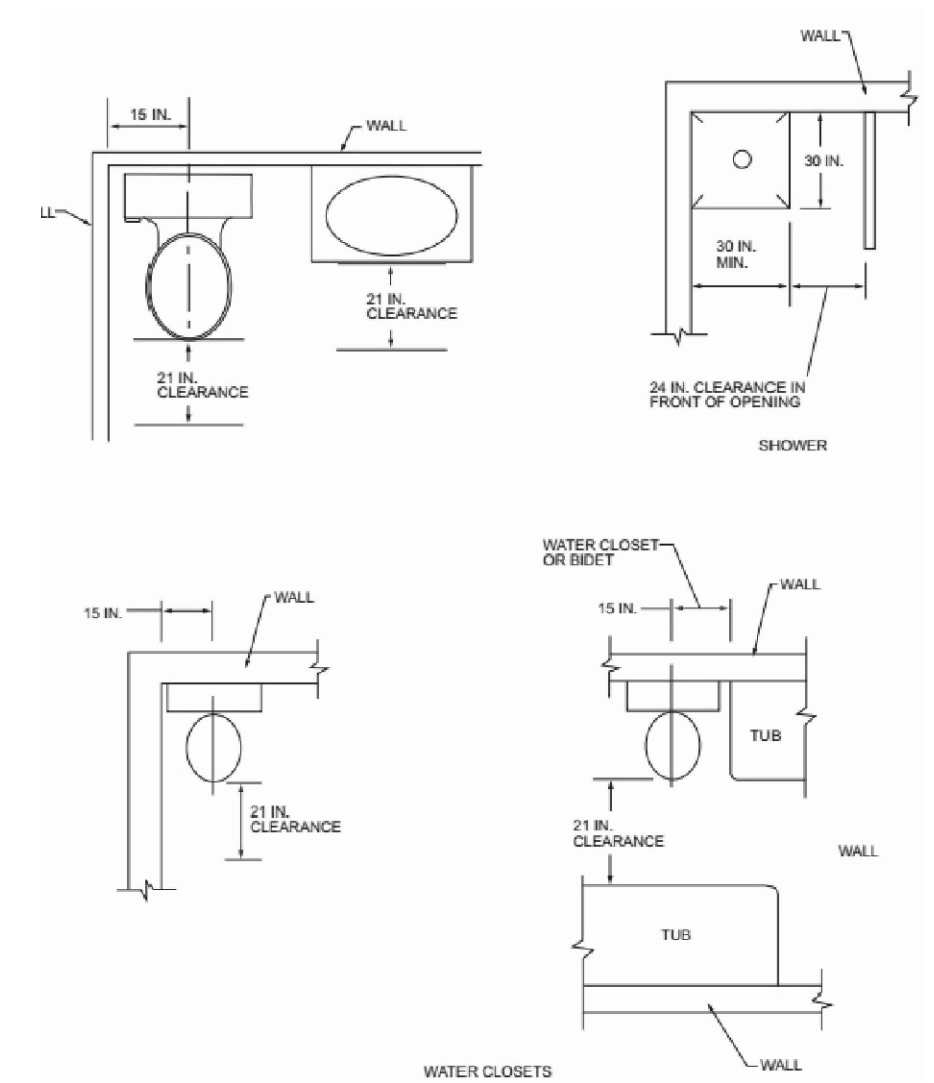

**PLUMBING FIXTURE CLEARANCES**

NO SCALE PER IRC FIGURE R321.1

**HVAC/PLUMBING GENERAL NOTES:**

1. THE MECHANICAL CONTRACTOR SHALL DETERMINE THE FINAL EQUIPMENT SIZING, DUCT SIZING, AND DUCT LAYOUT PRIOR TO INSTALLATION.
2. DRAIN AND VENT SIZES TO BE DETERMINED BY PLUMBING CONTRACTOR.
3. WATER HEATER RELIEF VALVE SHALL EXTEND OUTSIDE OF THE BUILDING WITH THE END OF THE PIPE NOT MORE THAN 2' NOR LESS THAN 6" ABOVE THE GROUND AND POINTING DOWNWARD.
4. PROVIDE A PAN, AND DRAIN FOR THE WATER HEATER.
5. THE CLOTHES DRYER EXHAUST DUCT SHALL BE AT LEAST THE DIAMETER OF THE APPLIANCE OUTLET AS RECOMMENDED BY THE MANUFACTURER AND SHALL TERMINATE AT THE EXTERIOR OF THE BUILDING. IT SHALL NOT EXCEED 25' IN LENGTH WITH REDUCTIONS FOR BENDS. THE DUCT SHALL TERMINATE NOT LESS THAN 3' FROM A PROPERTY LINE.
6. THE SITE PLAN SHALL INDICATE THE LOCATION OF THE GAS SOURCE, THE DISTANCE AND PIPE SIZE FROM THE SOURCE, TO THE RESIDENCE, AND THE TYPE OF FUEL (NATURAL GAS OR PROPANE).

1. BI-FOLD DOOR AT WATER HEATER CLOSET SHALL BE LOUVERED FOR COMBUSTION AIR (MIN. REQUIREMENTS OF 100 SQ. INCHES OF FREE AIR).

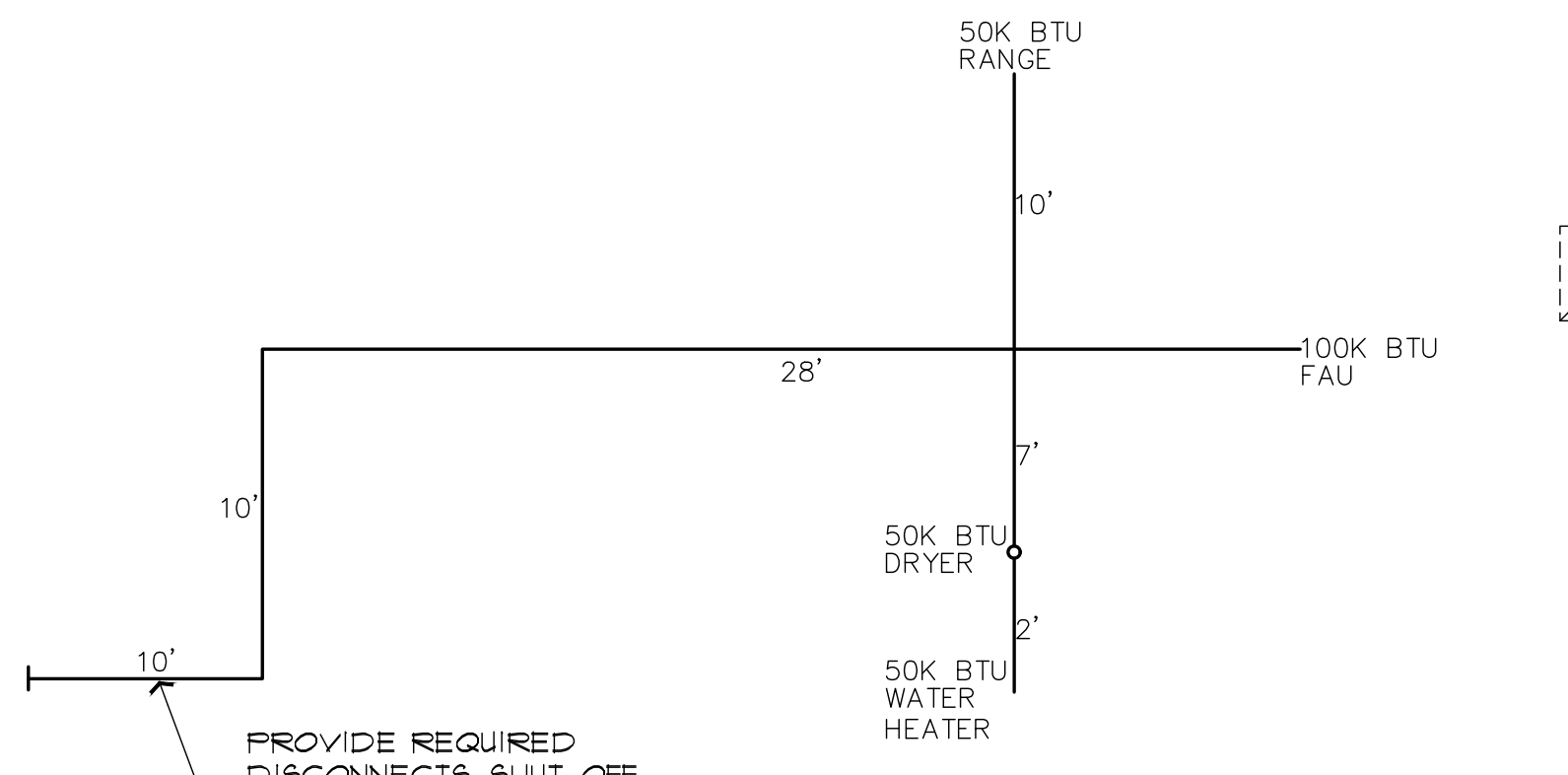

**GAS PIPING ISOMETRIC**

NO SCALE

NOTE: USE 1" DIA. PIPING FOR ALL FLOOR PLAN LAYOUTS.  
 THE PLUMBING CONTRACTOR SHALL VERIFY ALL SIZING, AND FITTINGS, PRIOR TO INSTALLATION.  
 NOTE: EXACT LENGTH FROM EXTERIOR OF STRUCTURE, TO GAS SOURCE, WILL VARY FOR EACH PROJECT. A REVISED GAS ISOMETRIC WILL BE REQUIRED IF THE LOCATION OF THE LP/NG SOURCE EXCEEDS 10' FROM THE STRUCTURE

LONGEST LENGTH METHOD G2413.4(1)  
 TABLE G2413.4(1)  
 250K TOTAL BTU LOAD  
 USE THE 10' TOTAL LENGTH  
 USE 1" DIA. PIPING

PROPERTY OF YAVAPAI COUNTY, AZ

This design is the sole property of Mark Rogers, Architect, PLLC. Use of this design has been granted to Yavapai County Government with the drawings provided. These drawings are not to be reproduced, or copied in whole or in part, for use by any entity other than Yavapai County Government. It is only to be used for the project and site specifically identified herein and is not to be used on any other project. It is to be returned upon request.

Mark Rogers, Architect, PLLC 2026

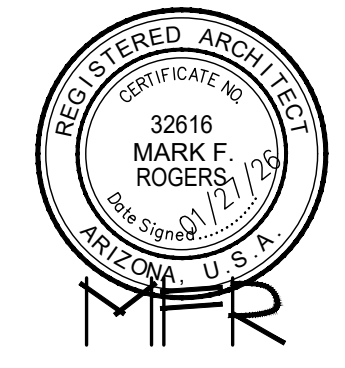

Mark Rogers, Architect, PLLC

761 Highland Circle  
 ♦♦♦ Chino Valley, Arizona 86323  
 Phone: (928) 848-3516  
 markrogers914@gmail.com

ELECTRICAL PLANS  
 SYMBOL SCHEDULE / NOTES  
 PHASE TWO - 3 BDRM / 2 BATH - LEFT PARKING

YAVAPAI COUNTY, ARIZONA

1015 FAIR STREET  
 PRESCOTT, ARIZONA

SHEET NO:  
**E-1.0**

200A ELEC. SES / PANEL  
 TO BE LOCATED AT EXTERIOR  
 WALL OUTSIDE BEDROOM 3

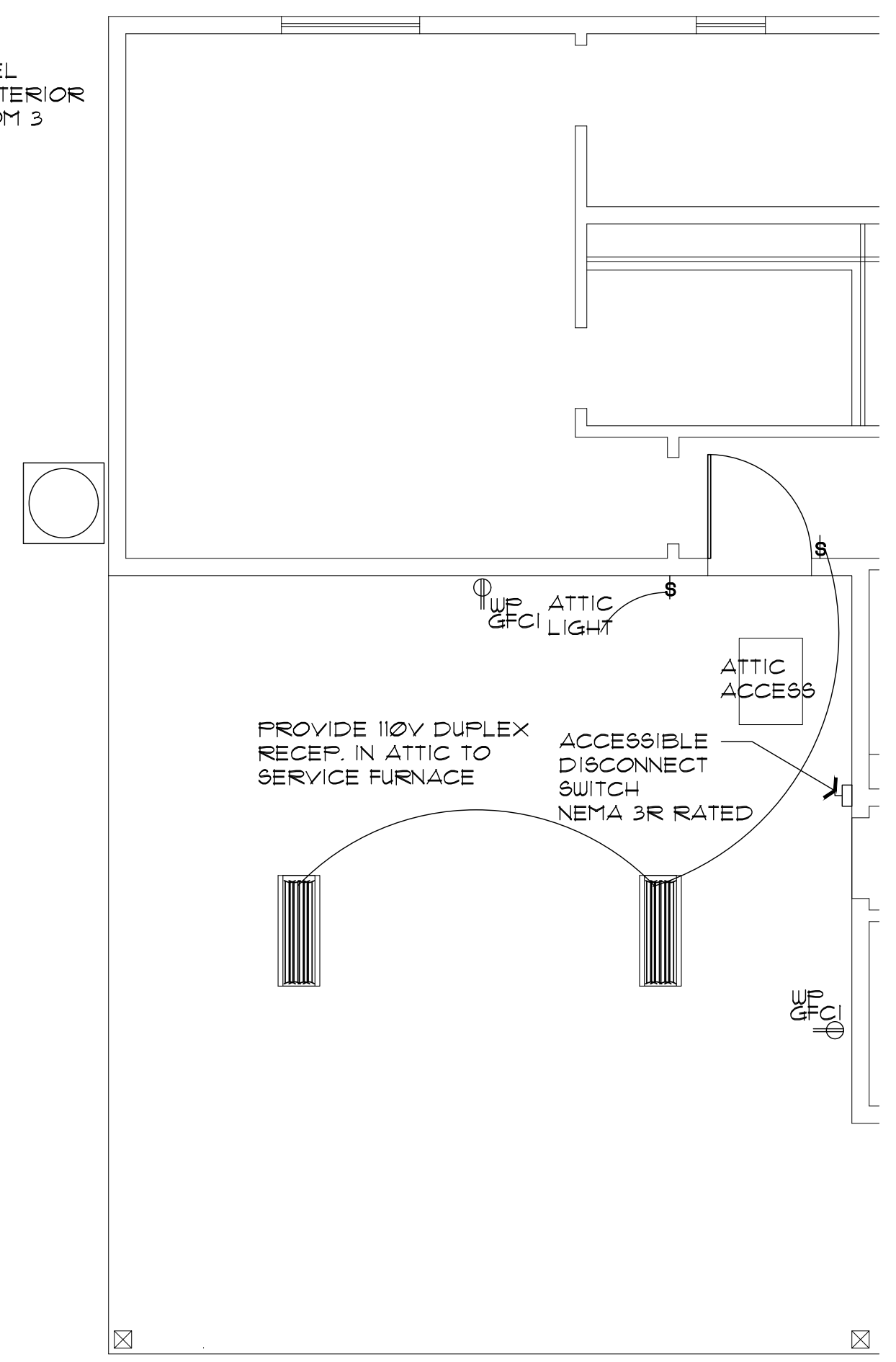

**PARTIAL ELECTRICAL PLAN (with Carport option)**

SCALE: 1/4" = 1'-0"

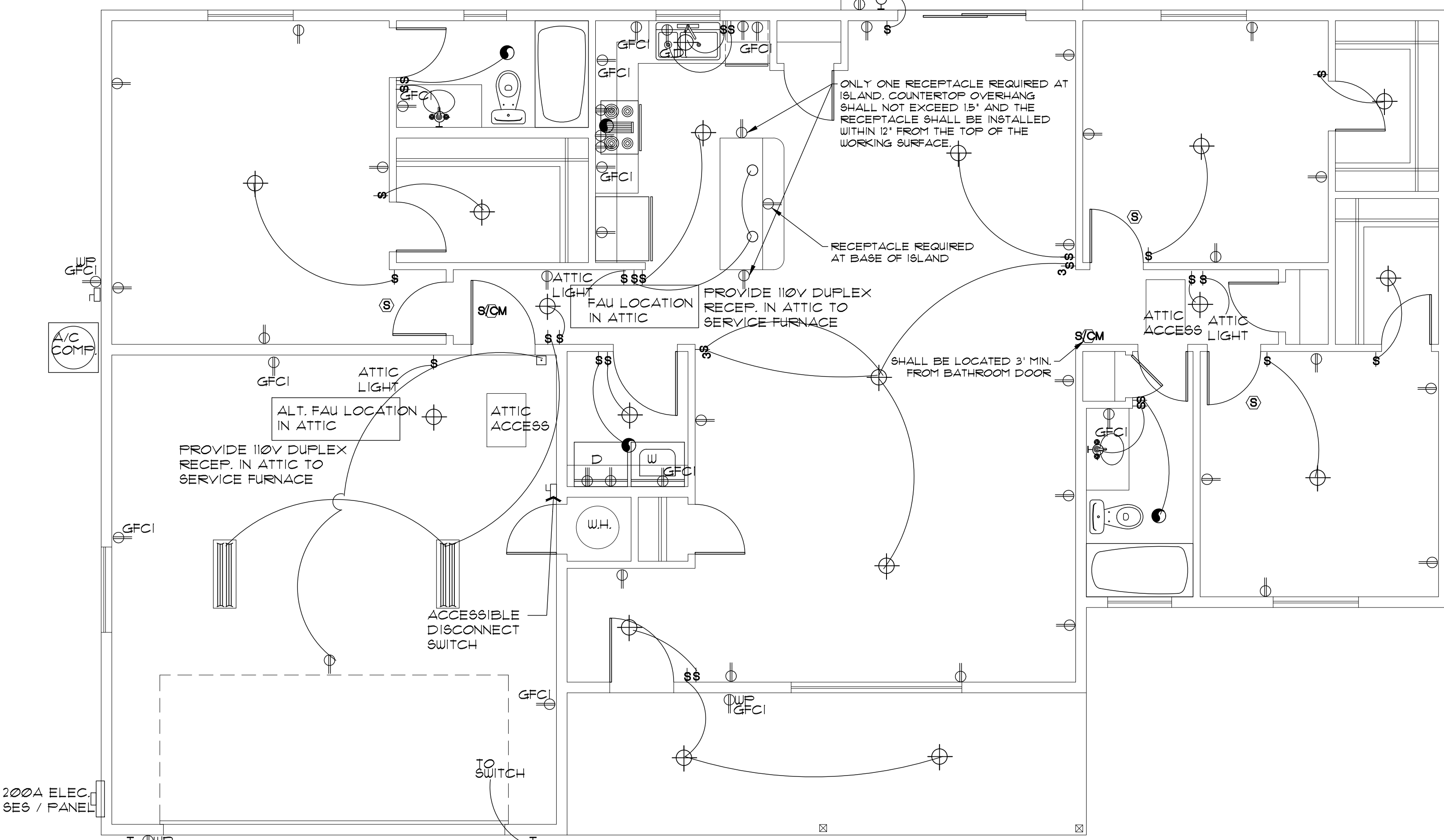

**ELECTRICAL PLAN (with Garage option)**

SCALE: 1/4" = 1'-0"

**ELECTRICAL SYMBOLS**

- ⊕ WALL MOUNTED LIGHT FIXTURE
- ⊕ CEILING MOUNTED LIGHT FIXTURE
- ⊕ DAMP-PROOF CEILING MOUNTED LIGHT FIXTURE
- ⊕ PENDANT LIGHT FIXTURE
- RECESSED CAN FIXTURE
- ▭ 1' x 4' SURFACE MTD. FLUORESCENT FIXTURE
- ⊕ 110V, DUPLEX CONVENIENCE OUTLET MOUNTED 12" AFF. OR AS NOTED
- ⊕ 110V, 4-FLX CONVENIENCE OUTLET MOUNTED 12" AFF. OR AS NOTED
- GFCI GROUND-FAULT INTERRUPT
- ⊕ W/P GFCI WEATHER-PROOF GROUND-FAULT INTERRUPT
- ⊕ 220V RECEPTACLE
- ⊕ SINGLE POLE SWITCH MOUNTED AT 48" OR AS NOTED
- ⊕ 3-WAY SINGLE POLE SWITCH MOUNTED AT 48" OR AS NOTED
- ⊕ CEILING EXHAUST FAN
- ⊕ SMOKE DETECTOR
- ⊕ SMOKE DETECTOR / CARBON MONOXIDE COMBO
- ⊕ CABLE TV OUTLET
- ⊕ CEILING FAN W/ LIGHT KIT
- ⊕ DOORBELL BUTTON
- ⊕ TELEPHONE OUTLET
- ⊕ INTERNET OUTLET

**ELECTRICAL GENERAL NOTES**

1. ALL WORKMANSHIP, MATERIALS, AND METHODS SHALL CONFORM TO N.E.C. - 2023 EDITION.
2. ALL HABITABLE ROOMS SHALL BE PROVIDED W/ ELECTRICAL OUTLETS SO THAT NO PART OF THE WALL IS MORE THAN 6' FROM AN OUTLET. WALL SECTIONS 2' OR LARGER 4 KITCHEN COUNTERS WIDER THAN 12' SHALL BE SERVICED BY A RECEPTACLE.
3. ALL RECEPTACLES IN BATHROOMS, OUTSIDE 4 WITHIN 6' OF WATER SOURCE SHALL BE G.F.C.I.
4. ALL SMOKE DETECTORS SHALL BE INTERCONNECTED ON SEPARATE CIRCUIT & SHALL RECEIVE PRIMARY POWER FROM BUILDING WIRING & SHALL HAVE BATTERY BACKUP. CONNECT NEW SMOKE DETECTORS TO NEW AUDIBLE SYSTEM INSIDE EXISTING RESIDENCE.
5. LIGHTS IN CLOSETS SHALL BE 18" FROM SHELVING (MEASURED HORIZTL. OR BE RECESSED).
6. PROVIDE MINIMUM TWO 20A BRANCH CIRCUITS FOR RECEPTACLES LOCATED IN THE KITCHEN, PANTRY, EATING AREA, A SEPARATE 20A BRANCH CIRCUIT TO THE LAUNDRY EQUIP., AND A SEPARATE 20A BRANCH CIRCUIT FOR BATHROOM RECEPTACLES.
7. ALL BRANCH CIRCUITS THAT SUPPLY 120-VOLT SINGLE PHASE 15 & 20 AMP OUTLETS INSTALLED IN FAMILY ROOMS, DINING ROOMS, LIVING ROOMS, PARLORS, LIBRARIES, DEN'S, BEDROOMS, SUNROOMS, RECREATION ROOMS, CLOSETS, HALLWAYS AND SIMILAR ROOMS OR AREAS SHALL BE PROTECTED BY COMBINATION TYPE AFCI FAULT CIRCUIT INTERRUPTERS INSTALLED TO PROVIDE PROTECTION.
8. FIXTURES, FITTINGS, BOXES AND RECEPTACLES LOCATED IN DAMP OR WET LOCATIONS SHALL BE 'LISTED' TO BE SUITABLE FOR SUCH CONDITIONS.
9. CONTRACTOR TO EMBED 20' OF #4 AWG COPPER WIRE IN FOOTING FOR ELECTRICAL SERVICE GROUND. PROVIDE BONDING TO THE INTERIOR WATER PIPING AND ABOVE GROUND PORTION OF GAS PIPING SYSTEM.
10. IN KITCHEN AND DINING ROOMS A RECEPTACLE OUTLET SHALL BE INSTALLED AT EACH WALL COUNTER SPACE 12" OR WIDER SO THAT AT NO POINT ALONG THE WALL IS MORE THAN 24" FROM A RECEPTACLE OUTLET AND SHALL BE GFCI PROTECTED.
11. PROVIDE AT LEAST ONE WEATHER PROOF RECEPTACLE OUTLET NOT MORE THAN 6'-6" ABOVE GRADE AND GFCI PROTECTED AT THE FRONT AND BACK OF EACH DWELLING. ALL RECEPTACLES INSTALLED OUTDOORS MUST BE GFCI PROTECTED.
12. ALL EXTERIOR LIGHTING SHALL CONFORM TO YAVAPAI COUNTY DARK SKY ORDINANCE.
13. IN ATTICS A SERVICE OUTLET & LIGHTING FIXTURE LOCATED NEAR THE APPLIANCE REQUIRING SERVICE SHALL BE CONTROLLED BY A SWITCH AT THE ENTRY OF THE ATTIC. (REQUIRED FOR ATTIC SERVICE FURNACES)

14. 125-VOLT THROUGH 250-VOLT RECEPTACLES THAT SERVE KITCHENS, FOOD AND/OR BEVERAGE PREPARATION AREAS, COOKING AREAS, AREAS LOCATED WITHIN 6' OF THE TOP INSIDE EDGE OF THE BOUL OF A SINK, WITHIN 6' OF THE OUTSIDE EDGE OF A SHOWER STALL OR BATHTUB, LAUNDRY AREAS, AND INDOOR DAMP AND WET LOCATIONS SERVED BY SINGLE-PHASE BRANCH CIRCUITS RATED 150 VOLTS OR LESS TO GROUND SHALL BE GFCI PROTECTED PER E3302.6-11
15. GFCI PROTECTION SHALL BE PROVIDED FOR THE BRANCH CIRCUIT OR OUTLETS SUPPLYING THE FOLLOWING APPLIANCES RATED 150 VOLTS OR LESS TO GROUND AND 20 AMPERES OR LESS SINGLE OR THREE-PHASE:
  - 15.1 DRINKING WATER COOLERS AND BOTTLE FILL STATIONS
  - 15.2 HIGH-PRESSURE SPRAY WASHING MACHINES
  - 15.3 SUMP PUMPS
  - 15.4 DISHWASHERS
  - 15.5 ELECTRIC RANGES
  - 15.6 WALL-MOUNTED OVENS
  - 15.7 COUNTER-MOUNTED COOKING UNITS
  - 15.8 CLOTHES DRYERS
  - 15.9 MICROWAVE OVENS
16. WHOLE HOUSE SURGE PROTECTION REQUIRED PER E3606.5

**REVIEWED FOR DESIGN CRITERIA ONLY**  
 SEE ATTACHED COVER SHEET FOR ALL STAMPS. IT IS THE RESPONSIBILITY OF THE OWNER/APPLICANT TO REVIEW AND ACKNOWLEDGE APPLICABLE STAMPS.

MAIN HOUSE LOAD CALC'S	
RESIDENCE 1613 SQ FT @ 3 WPST	4839 WATTS
ALTERNATE GARAGE 483 SQ. FT. @ 2 WPSF	966 WATTS
TOTAL=	5805 WATTS
APPLIANCE CKTS (2)=	3000
RANGE-OVEN (1)=	12000
REFRIGERATOR (1)=	1500
MICROWAVE (1)=	1500
DISHWASHER (1)=	1500
DISPOSALS (1)=	1500
WASHER (1)=	1500
DRYER (1)=	5000
WATER HEATER (1)	4500
LAUNDRY CIRCUIT (1)=	1500
ALT 1 GARAGE DOOR OPENER=	1500
EV CHARGER (1)=	7200
TOTAL GEN LOAD=	48005
1ST 10000 WATTS @ 100%=	10000 WATTS
REMAINING 38005 @ 40%=	15202
1ST C/U & A/H (3T OR 10KW HEAT STRIP)=	14000
TOTAL LOAD=	39202
39202/240VAC=	163.34 AMPS
<b>200 AMP SERVICE ADEQUATE</b>	

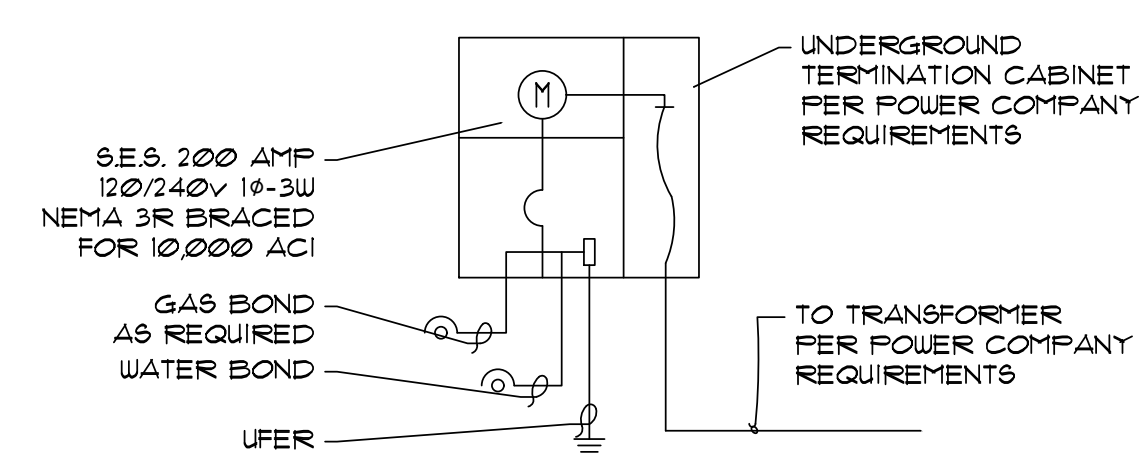

**A** NEW 200 AMP 120/240V1Ø3W NEMA 3R SES BRACED FOR 10000 AIC